



REGIONAL WOOD ENERGY DEVELOPMENT PROGRAMME IN ASIA
GCP/RAS/154/NET



CHINESE FUEL SAVING STOVES: A COMPENDIUM



This publication is printed by
the FAO Regional Wood Energy Development Programme in Asia,
Bangkok, Thailand

The designations employed and the presentation of material in this publication do not imply the expression of any opinion whatsoever on the part of the Food and Agriculture Organization of the United Nations concerning the legal status of any country, territory, city or area or of its authorities, or concerning the delimitations of its frontiers or boundaries.

The opinions expressed in this publication are those of the author(s) alone and do not imply any opinion on the part of the FAO.

For copies write to: Regional Wood Energy Development
Programme in Asia
c/o FAO Regional Office for Asia and the Pacific
Maliwan Mansion, Phra Atit Road,
Bangkok, Thailand

Tel: 66-2-280 2760
Fax: 66-2-280 0760
E-mail: rwedp@fao.org
Internet: <http://www.rwedp.org>

FOREWORD

Most countries in Asia are giving an increasingly higher priority to energy conservation, both in the industrial/commercial and domestic sectors. As cooking in developing countries constitutes a large part of the total energy consumption in the domestic sector, conservation approaches have concentrated on the development and introduction of improved cooking stoves.

From its very beginning in 1985 the Regional Wood Energy Development Programme in Asia (RWEDP) has supported or initiated activities in the field of improved cookstoves development, with particular emphasis on information sharing and transfer of knowledge. The "Regional Expert Consultation on Improved Cookstove Development Programmes in South Asian Countries", which was held in Udaipur, India in 1991, recommended that national stove compendiums should be prepared and adopted as part of a regional cooperative commitment to sharing information. We are very pleased that, by preparing the present document, China has come forward in fulfilling this spirit of regional cooperation.

China's cookstove development and dissemination programme, with 140 million stoves reportedly installed in rural households, accounts for some 70-80% of the total number of improved cookstoves installed worldwide. Not only is the number of stoves impressive, but the variety of models to suit the diverse geographical conditions and users' needs and preferences is exemplary also. At the same time considerable investments have been made in institutional arrangements with over 200,000 persons reportedly being directly involved in the programme.

We are very grateful to the Chinese Academy of Agricultural Engineering Research and Planning (CAAERP) for all the information provided and especially to the members of the editorial team who compiled this comprehensive and informative overview, namely: Mr. Yoa Xiangjun, Dr. Wang Mengjie, Mr. Hao Fangzhou and Prof. Zhang Jigao. The final text editing and layout for publication were carried out by Dr. Aroon Chomcharn, Ms. Panpicha Issawasopon, Ms. Pimpa Molkul and Ms. Navaporn Liangcheevasoonthorn.

It is hoped that this report will be useful for all those officials and volunteers in Asia and beyond who are engaged in designing or implementing programmes for introducing energy saving cookstoves as part of an overall effort to improve life for the rural poor. Any comments or other feedback from readers will be highly appreciated.

Egbert Pelinck
Chief Technical Adviser

PREFACE

At present, most Chinese people living in rural areas still prefer to use biomass fuel-saving cookstoves to alleviate fuel shortages and to improve general sanitary conditions in their kitchens. Even though there is a tendency for the relatively rich rural farm and small town households to switch to coal for cooking and space heating, biomass, especially fuelwood and agri-residues, is still a major domestic fuel and will remain so in the foreseeable future. Since the early eighties, the central government authorities comprising the State Planning Commission, the Ministry of Agriculture, the Ministry of Forestry, the State Commission for Science and Technology, the Ministry of Energy and the Ministry of Finance have made a coordinated national effort to develop and disseminate fuel-saving stoves with the active involvement of various national, state and local institutions (eg. administrative departments, scientific and technical research institutes, training institutes, and the industrial service and manufacturing sectors). As a result, by the end of 1991, about 142.56 million farm households had adopted fuel-saving stoves, or equivalent to about 70% of the total number of farm households in China. It has been estimated that the improved stoves, so far disseminated, save annually about 60 million metric tons of energy in coal equivalent, or about 100 million tons in fuelwood equivalent. Furthermore, the use of improved stoves, which allow more complete combustion of biomass and coal fuels, has substantially contributed to a reduction in environmental pollution. Other benefits derived from the use of the improved stoves include: time savings due to faster cooking and less collection of biomass fuels, the enhancement of soil fertility by returning the crop residues saved to the field and, as a whole, the development of the rural economy and the improvement in farmers' living conditions in rural China.

The earlier compendium, "Chinese Fuel Saving Stoves", published in 1986 by the FAO Regional Office for Asia and the Pacific, introduced eight selected models of advanced fuel-saving stoves that were popularly used in farm households during the 6th Five-year Plan (1980-1985). The purpose of that publication was to promote technical cooperation and the exchange of information between China and other countries in Asia as well as in other regions. In this present compendium, ten new models of high efficiency stoves that have been developed during 1986-1992 are presented. It should be noted that all the improved stoves in China have their main parts, or all the parts in many cases, prefabricated from cast iron and/or refractory ceramics and concrete slabs. This production strategy helps not only to maintain the stoves' critical dimensions and service-lives, but also enables the stoves to be sold in the market similar to other household commodities. While most of the models chosen are biomass-fired cookstoves, two coal-fired models are also introduced: one for institutional cooking and the other for cooking and space heating in the household. A newly developed industrial wood- or briquette-fired furnace for crop drying applications is also included.

The Chinese Rural Energy Authorities hope that the information presented in this compendium will be of interest to a wide variety of readers. We are happy to share and exchange our experience with other developing countries, especially in the field of improved cookstoves and energy conservation.

Dr. Wang Mengjie
Deputy Director CAAERP, Beijing

TABLE OF CONTENTS

	Page
FOREWORD	i
PREFACE	ii
1 DEVELOPMENT BACKGROUND OF IMPROVED COOKSTOVE IN CHINA	1
2 RECENT MODELS OF IMPROVED COOKSTOVE IN CHINA	5
2.1 Model PT High-Efficiency Composite Stove	5
2.2 Model FL Series Fuel-Saving Composite Stove	11
2.3 Model WS Fuel-Saving Composite Stove	17
2.4 Model YS High-Efficiency Composite Stove	19
2.5 Model Suizhou-400 Commercial Fuel-Saving Stove	24
2.6 Model WH Series Fuel-Efficient Composite Stove	27
2.7 Institutional Coal-Saving Cookstove	31
2.8 Summaries of General and Technical Features of Fuel-Saving Cookstoves	32
3 SELECTED IMPROVED STOVES FOR COOKING/SPACE HEATING	34
3.1 Domestic Fuel-Saving Heating Stove	34
3.2 Model LX Cooking/Heating Coal Stove	38
3.3 Model KSL High-Efficiency Industrial Furnace	40
3.4 Summaries of General and Technical Features of Fuel-Saving Cooking/Heating Stoves	42
4 CHINA IMPROVED COOKSTOVE ORGANIZATION AND NETWORK	43
4.1 National Organization Chart	44
4.2 National Stove Programme Management	45
4.3 Stove Research and Development Institutes/Universities	45
4.4 Provincial and Municipal Promotional Organization	46
4.5 Major Improved Stove Manufacturers	48
4.6 Leading Experts on Improved Stoves in China	49
5 REFERENCES	50
Annex 1: State Standard of the People's Republic of China Testing Method for the Heat Properties of Civil Firewood Stoves	51
Annex 2: Relationship between lower calorific value and the moisture content of biomass fuels often used in China	57

1 DEVELOPMENT BACKGROUND OF IMPROVED COOKSTOVE IN CHINA

In rural areas of China, where more than 800 million farmers live, biomass energy in the form of fuelwood, leaves, agri-residues and other organic wastes are widely used both for domestic cooking and agricultural/small industrial processing activities. Although China has vast coal reserves which have been extensively used for various applications, including in the domestic sector, due to their limited distribution and the high cost involved, most farmers still find biofuels more convenient to procure and/or cheaper to use at household level.

Therefore, it is not surprising that a very large quantity of such biomass fuels is still used. As late as 1988, it was estimated that the energy consumption in rural areas accounted for 524 million tons of coal equivalent (TCE) of which 56.8% was derived from biomass fuels. If this amount of biomass was converted to fuelwood, this would amount to some 580 million tons of wood equivalent (TWE). While the annual growth of forests in China amounts to some 330 million cubic meters, about 100 million TWE or about 40-50% of that amount is burnt as fuel by farmers. Still biomass fuels are not sufficient for rural use.

In an effort to conserve biomass fuels, China embarked a national programme on improved cookstove development in the early eighties. By 1983 a sizable number of households had adopted improved cookstoves. After a decade of continuous effort, at the end of 1991 about 148.585 million households, mostly in rural areas, had acquired and/or had experience with improved cookstoves. Yearly rates for cookstove adoption between 1983 and 1991 are shown in figure 1.1 below. It should be pointed out that the figures provided in table 1.1 do not exclude stoves that have reached the end of their service life. This will be discussed further in section 1.2. The detailed distribution of firewood-saving cookstoves in 1991, by province, is shown in table 1.1 and the stove models recommended in major provinces and cities are presented in table 1.2:

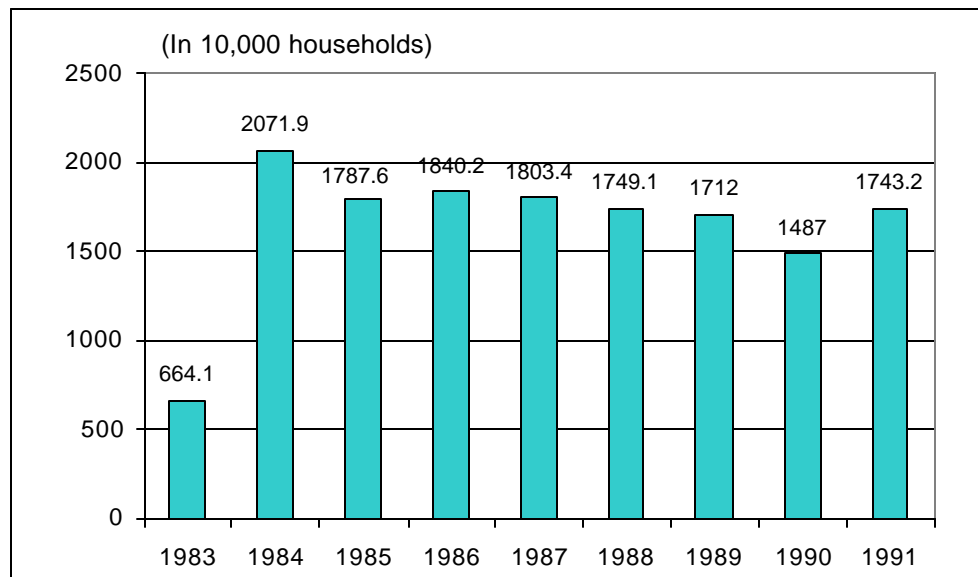
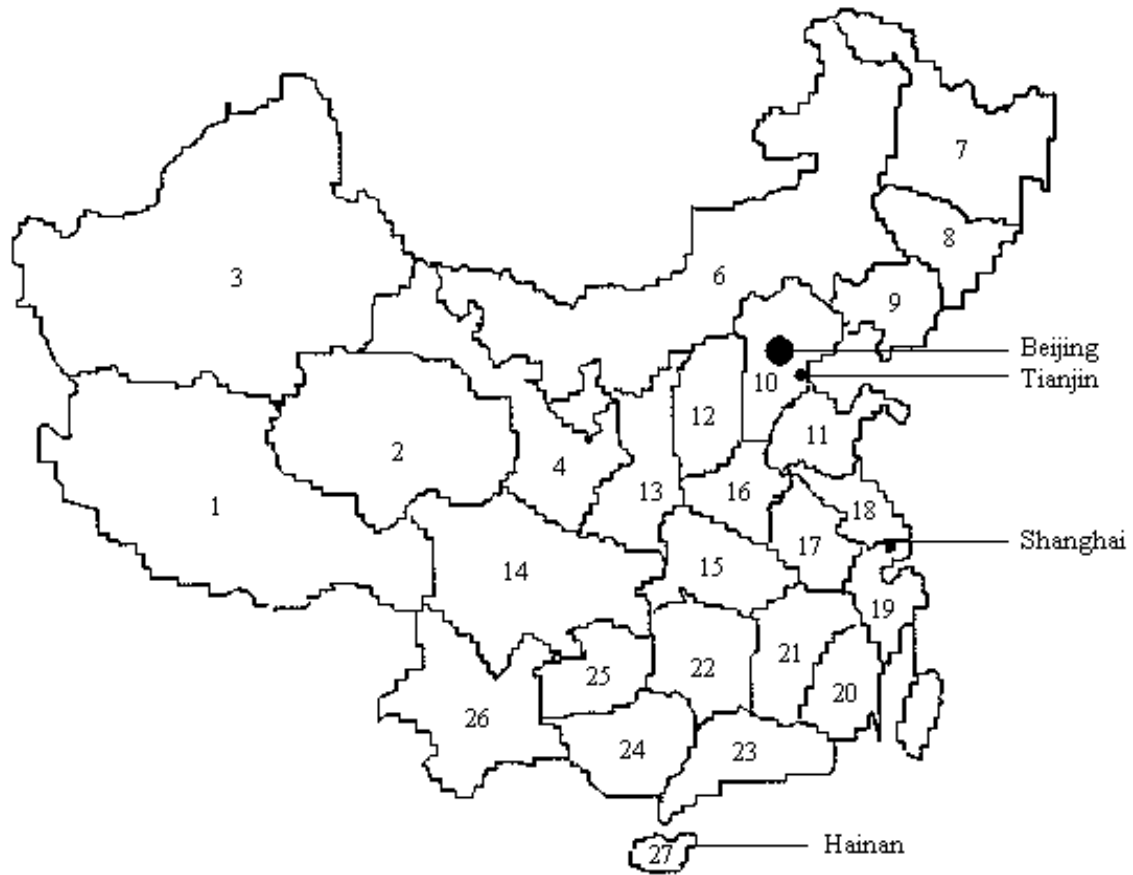

Figure 1.1: Number of households which adopted firewood-saving cookstoves in China, 1983-1991



- | | | | |
|-------------------|-----------------|-------------|---------------|
| 1. Tibet | 7. Heilongjiang | 13. Shanxi | 19. Zhejiang |
| 2. Qinghai | 8. Jilin | 14. Sichuan | 20. Fujian |
| 3. Xinjiang | 9. Liaoning | 15. Hubei | 21. Jiangxi |
| 4. Gansu | 10. Hebei | 16. Henan | 22. Hunan |
| 5. Ningxia | 11. Shandong | 17. Anhui | 23. Guangdong |
| 6. Inner Mongolia | 12. Shanxi | 18. Jiangsu | 24. Guangxi |
| | | | 25. Guizhou |
| | | | 26. Yunnan |
| | | | 27. Hainan |

Figure 1.2: Provinces and Autonomous Regions of China

Table 1.1: Status of Fuel-Saving Stove Dissemination in 1991

Unit: in 10,000

Province/City	Accumulated Number at Beginning of 1991	Number Disseminated in 1991	Number Out of Use in 1991	Accumulated Number at End of 1991
Beijing City	76.69	8.51	14.20	71.00
Tianjin City	33.56	1.97	0.36	35.17
Hebei	607.00	82.50	10.08	679.42
Shanxi	113.00	10.54	5.82	117.72
Neimeng	166.06	3.77	3.02	176.81
Liaoning	392.72	17.61	4.04	406.32
Shenyang City	47.24	0.03		47.27
Dalian City	81.52	3.82	3.24	82.10
Jilin	218.06	9.84	5.60	221.80
Changchun City	75.73	7.50	3.12	80.11
Heilongjiang	317.71	25.17	2.32	340.56
Hafabin City	18.72	0.45	3.10	16.07
Shanghai City	107.94	0.88	0.08	108.74
Jiangsu	713.91	187.95	30.34	871.52
Nanjing City	24.41	0.09	0.32	30.18
Zhejiang	583.41	80.28	0.94	656.75
Ningbo City	59.74	18.05	0.01	77.78
Anhui	961.34	153.34	125.89	988.79
Fujian	210.35	29.94	1.36	238.93
Xiamen City	18.33	0.23		18.56
Jiangxi	365.28	69.59	22.52	412.35
Shandong	1,341.16	122.61	6.17	1,457.60
Qingdao City	117.90	25.39	0.12	143.17
Henan	1,031.08	159.34	21.23	1,169.19
Hubei	751.41	89.80	32.33	808.88
Wuhan City	60.86	5.85	4.85	61.86
Hunan	1,021.40	124.09	16.48	1,129.01
Guangdong	630.95	87.59	7.54	711.00
Guangzhaan City	48.80			48.80
Guangxi	353.23	99.20	10.80	441.63
Hainan	51.29	13.06	5.54	58.81
Sichuan	955.95	146.90	8.18	1,094.67
Chengdo City	74.47	7.39	1.60	80.26
Chongqing City	132.36	16.55	0.79	148.12
Gueizhen	148.20			
Yunan	197.56	28.58	9.81	216.33
Xizang				
Shanxi	307.04	67.03	0.74	373.33
Xian City	23.90			
Gansu	272.44	13.72	3.43	282.73
Qinghai	24.40	0.15		24.55
Ningxia	34.03	0.00		34.06
Xinjiang	115.98	8.36	2.25	122.09
Total	12,887.13	1,743.21	368.22	14,084.04

Source: 1992 Statistics of the Ministry of Agriculture

Table 1.2: The Stove Models Recommended in Selected Provinces and Cities

Province/City	Recommended Stove Models
Anhui	Model Suxian-II Firewood Efficient Stove
Beijing	Model Tongzhou-II Kang Combined Stove Model Huafeng Cooking/Heating Coal Stove Model LX Cooking/Heating Coal Stove Model Dongbao Cooking/Heating Coal Stove
Guangdong	Model WH Series Fuel-Efficient Composite Stoves Model NG Composite Fuel-Efficient Stove Series Model CS Twin-Pot Fire-Backing Stove
Guangxi	Double Dragon Model ZWL Energy-Saving Double-Body Stove Model HP-IV Step-Style Fuel-Efficient Stove
Heilongjiang	Model HLJ-I Kang Combined Stove Model BY Kang Combined Stove Model HL Arch-Shaped Energy-Saving Stove
Henan	Model Yunongneng-I Step-Style Firewood-Efficient Stove Model ZP Crescent Moon-Shaped Firewood-Saving Stove
Hubei	Model KD-III Composite Firewood-Efficient Stove Model Suizhou-400 Commercial Wood-Saving Stove Model Yinshan-I Fuel-Saving Stove
Hunan	Model Yue-II Firewood-Saving Stove Model Yue-III Firewood-Saving Stove
Liaoning	Ladder-Shaped Energy-Saving Stove
Qinghai	Model Xunhua-II Firewood-Saving Stove Hualong Firewood-Straw Combined Stove
Shandong	Model Rongcheng-II Fuel-Efficient Stove Model WS Energy-Saving Composite Stove
Shanghai	Twin-Pot Fire-Backing Stove
Sichuan	Liangshan Boat-Shaped Stove Pengxi Sanitary Stove
Zhejiang	Model ZT Energy-Saving Stove with Attached Water Tank Model YK-II Fuel-Efficient Stove

2 RECENT MODELS OF IMPROVED COOKSTOVE IN CHINA

As mentioned earlier, during 1985-86 China compiled a catalogue on improved cookstoves, entitled "Chinese Fuel Saving Stoves" (FAO 1986). Since then, based on feedback from users, manufacturers and dissemination agents as well as from research scientists, more and/or advanced models of improved cookstoves have evolved to accommodate the diverse needs of users and to overcome weaknesses of some previous models. While keeping in mind that many of those original models are still valid today, in this compilation the editorial team of CAAERP has focused on new models that reflect the most recent developments so that readers may obtain maximum benefit from this new source of information.

In all, ten models/series are included, namely: models for cooking only, models for cooking and space heating, models for space heating only and, lastly, a new special furnace designed for a wide range of applications in crop processing or other process heat generation.

2.1 Model PT High-Efficiency Composite Stove

The traditional stove built with brick and clay, widely adopted by farm households in Pingtan and its adjacent counties along the sea coast of Fujian Province (south-eastern China), has many weaknesses, e.g. its fire fencing ring made of clay is often broken, it has a short service life and low thermal efficiency.

The Model PT High-Efficiency Composite is a single pot chimneyed stove with a fire fencing ring made of cast iron. It was developed by the Rural Energy Office of Pingtan County in 1988. The model has two designs: the Model PT-I with front chimney and the Model PT-II with rear chimney. At present, over 10,000 stoves have been disseminated in Pingtan County and its neighboring Putian City.

The cast iron fire fencing ring and its fittings cost about RMB 20-25 Yuan (US\$ 3.5-4.4)¹. The total cost of a stove is about RMB 170-200 Yuan. A trained worker can install a stove in 1.5 man-days. The Model PT can be used with various forms of biomass fuels, eg. firewood, agri-residues, weeds and leaves. It consumes about 0.5-0.6 kg fuels (with a lower calorific value of 3,300 kcal/kg)² to boil 5 kg water in 8-10 minutes, using a 62 cm. diameter iron cauldron. In order to facilitate a more complete fuel burning, the stove can be equipped with a bellows or air blower.

The general and main technical features of the Model PT-I and PT-II are summarized in table 2.1 and 2.2. **Illustrations and technical drawings** are shown in figures 2.1- 2.5 below.

¹ 1 US\$ = 5.73 RMB Yuan

² For lower calorific values of various biomass fuels, please refer to annex 2.

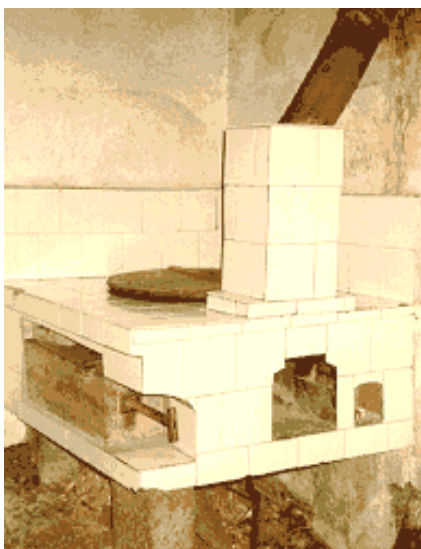

a) General appearance of the stove after installation showing firing port, air blower, cooking cauldron with wooden lid in place, and chimney



b) Starting ignition by using a manually operated wooden air blower

Figure 2.1 a) and b): Model PT-I, High-Efficiency Composite Stove (with front chimney)



a) *General appearance of the stove after installation with the (rear) chimney hidden by the wall. The cooking cauldron sits tightly over the combustion chamber and a space is provided for the air blower and the firing port*

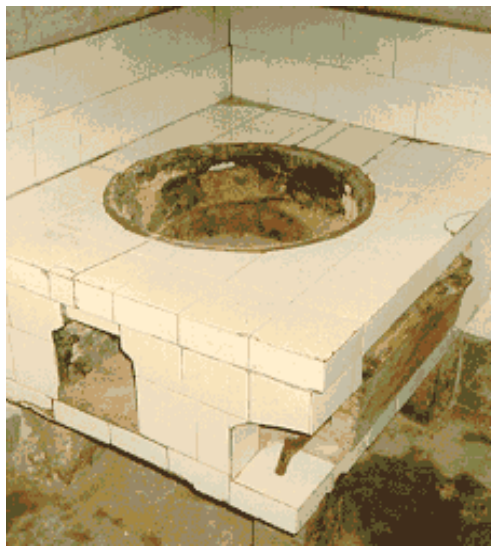

b) *Close-up of the combustion chamber showing the exhaust gas exit*

Figure 2.2 a) and b): Model PT-II, High-Efficiency Composite Stove (with rear chimney)

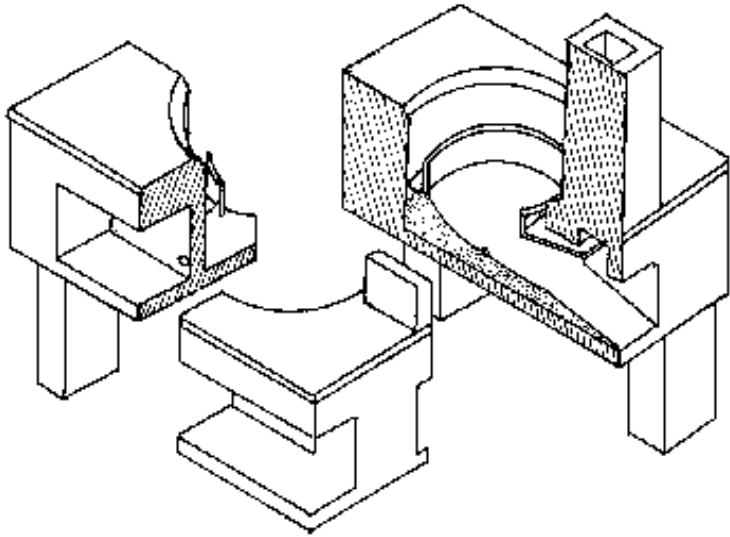

a) Model PT-I

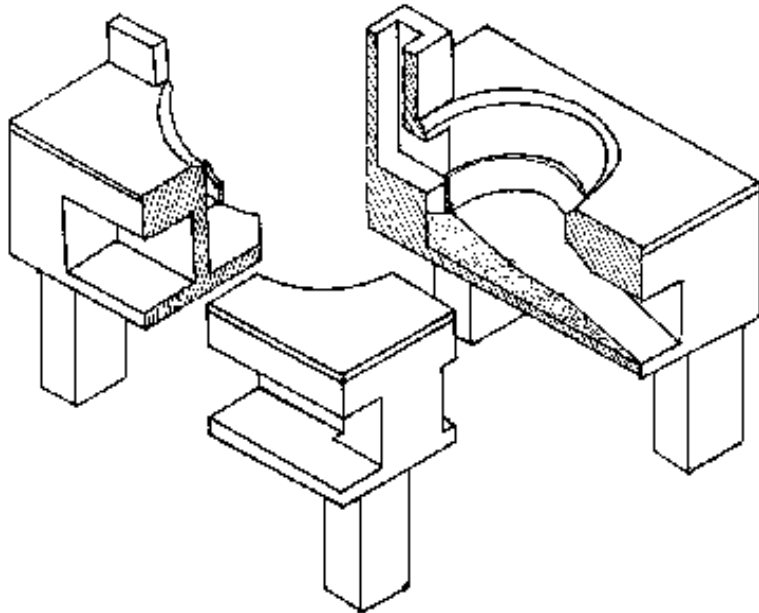

b) Model PT-II

Figure 2.3: Perspective views of a) Model PT-I and b) Model PT-II

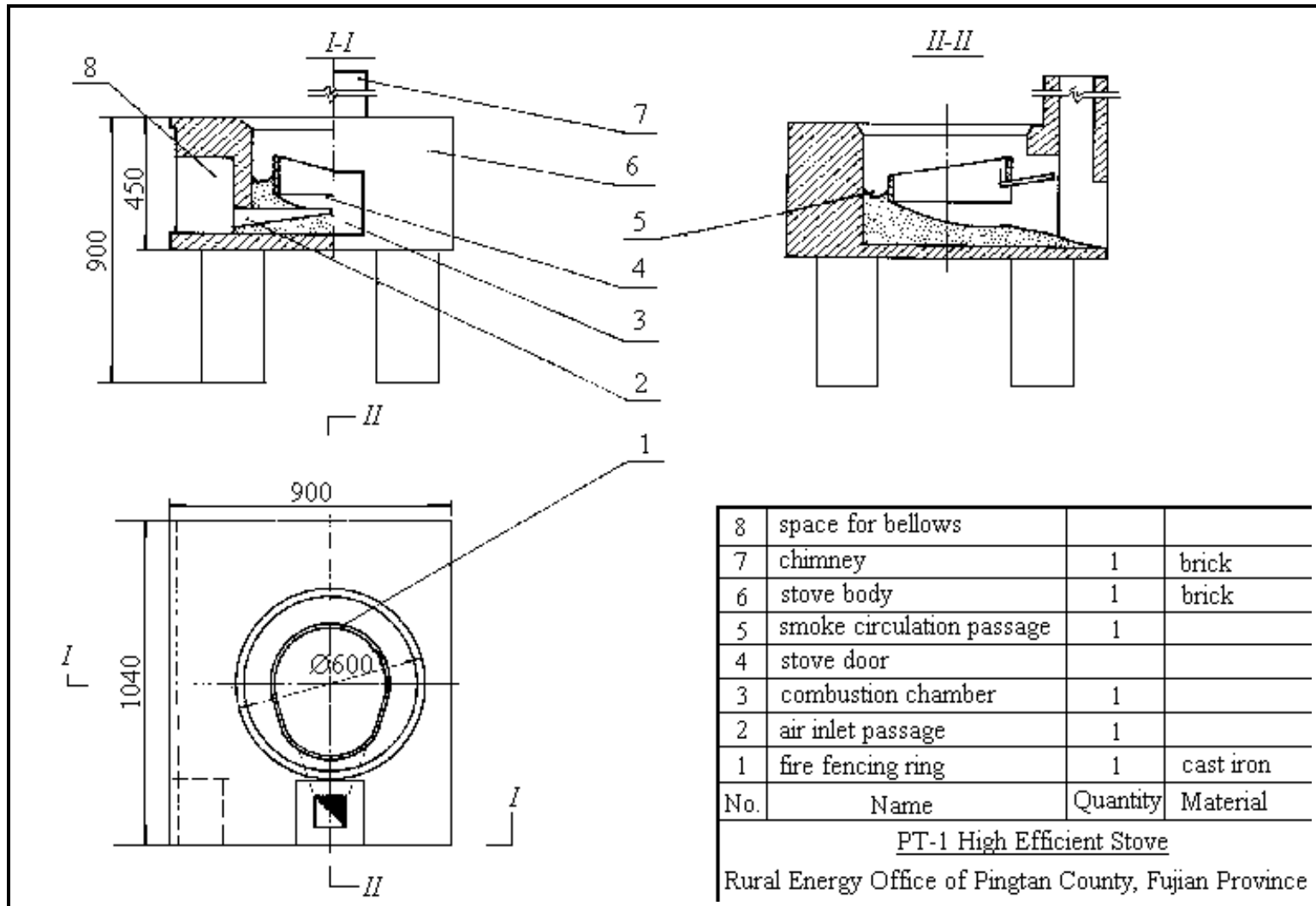

Figure 2.4: Technical drawings of Model PT - I, High-Efficiency Composite Stove

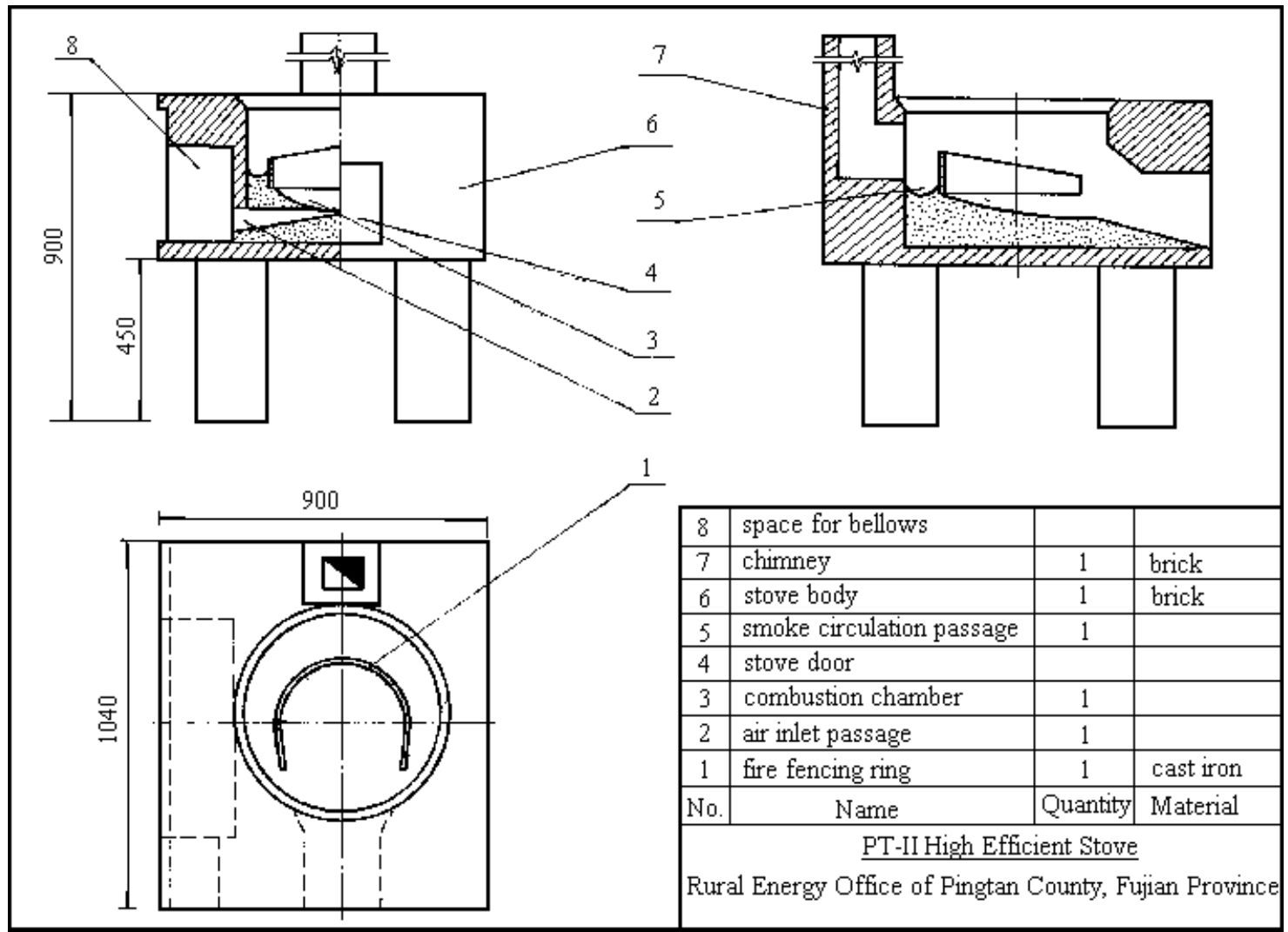

Figure 2.5: Technical drawings of Model PT-II, High-Efficiency Composite Stove

2.2 Model FL Series Fuel-Saving Composite Stove

Improved cookstove promotion in Wenchang County of Hainan Province (the southern island province of China) began in 1982. At first the improved stoves which were disseminated were mainly built *in situ*. Because of varying technical skills among the stove builders, the quality of the stoves was uneven and the technical specifications were hardly ever met. The end result was often poorly performing stoves.

The Model FL is a single-pot chimneyed stove developed, in line with the local cooking customs and related cooking vessels, by the Energy Conservation Office of Wenchang County. Basically the model has two designs: the Model FL Partial Composite Stove (FL-PCS) developed in 1987 and the Model FL Complete Composite Stove (FL-CCS) developed in 1990.

The combustion chamber and grate of the Model FL-PCS are made of cast iron while other parts have to be self-built. A combustion chamber costs about RMB 12 Yuan and needs 1 man-hour for casting. The total construction cost for a stove is about RMB 100 Yuan. Compared to the original manually built stove, the Model FL-PCS can save 3 man-hours for construction. At present, this model has been disseminated to over 65,000 households both in mountainous/hilly regions and in the plains.

The Model FL-CCS on the other hand has a complete set of cast iron parts and a chimney ready for installation. It can be fired with firewood and residue fuels. It is suitable for use with either an iron cauldron or an aluminum cylindrical pot. The average heat utilization efficiency (HU) reaches about 28%. The total cost of the stove is about RMB 45 Yuan, inclusive of a 2.5 meter-long steel chimney.

The general and main technical features of the Model FL-PCS and FL- CCS are summarized in table 2.1 and 2.2. Illustrations and technical drawings are shown in figures 2.6-2.11 below.



Figure 2.6 a): Front view of Model FL-PCS



Figure 2.6 b): Model FL-PCS in use



Figure 2.7 a): Cast-iron parts of Model FL-PCS showing structure of the combustion chamber



Figure 2.7 b): Cast iron parts of Model FL-PCS, showing grates of different sizes

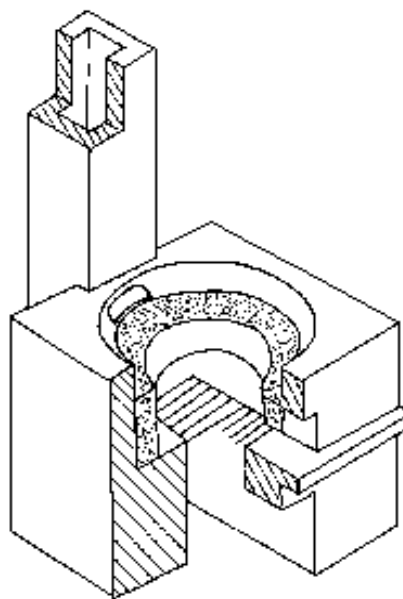

Figure 2.8: A perspective view of Model FL-PCS

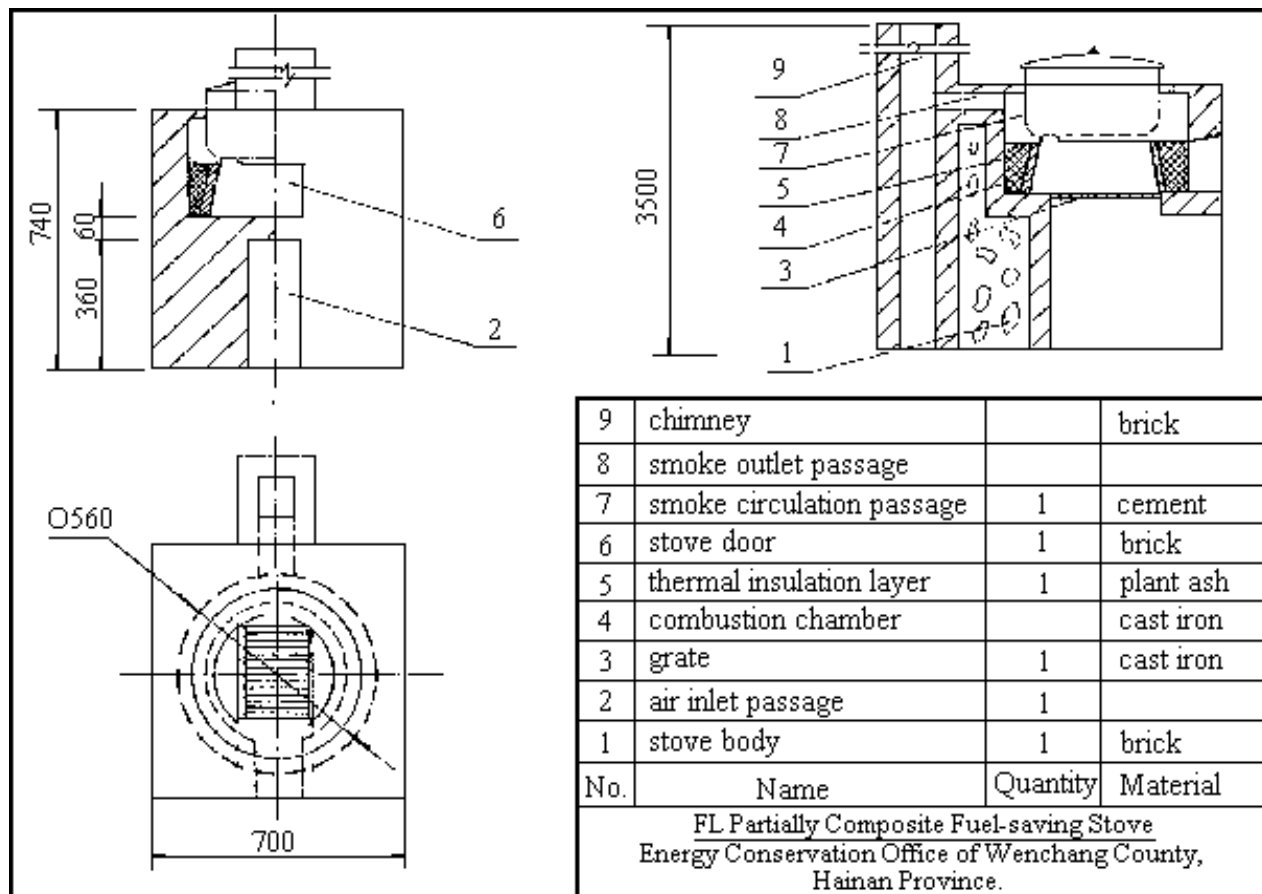

Figure 2.9: Technical drawings of Model FL-PCS



Figure 2.10 a): Model FL-CCS showing complete metal parts



b) Structure of combustion chamber



c) Individual cast iron parts

Figure 2.10 b) and c): Various components of Model FL-CCS

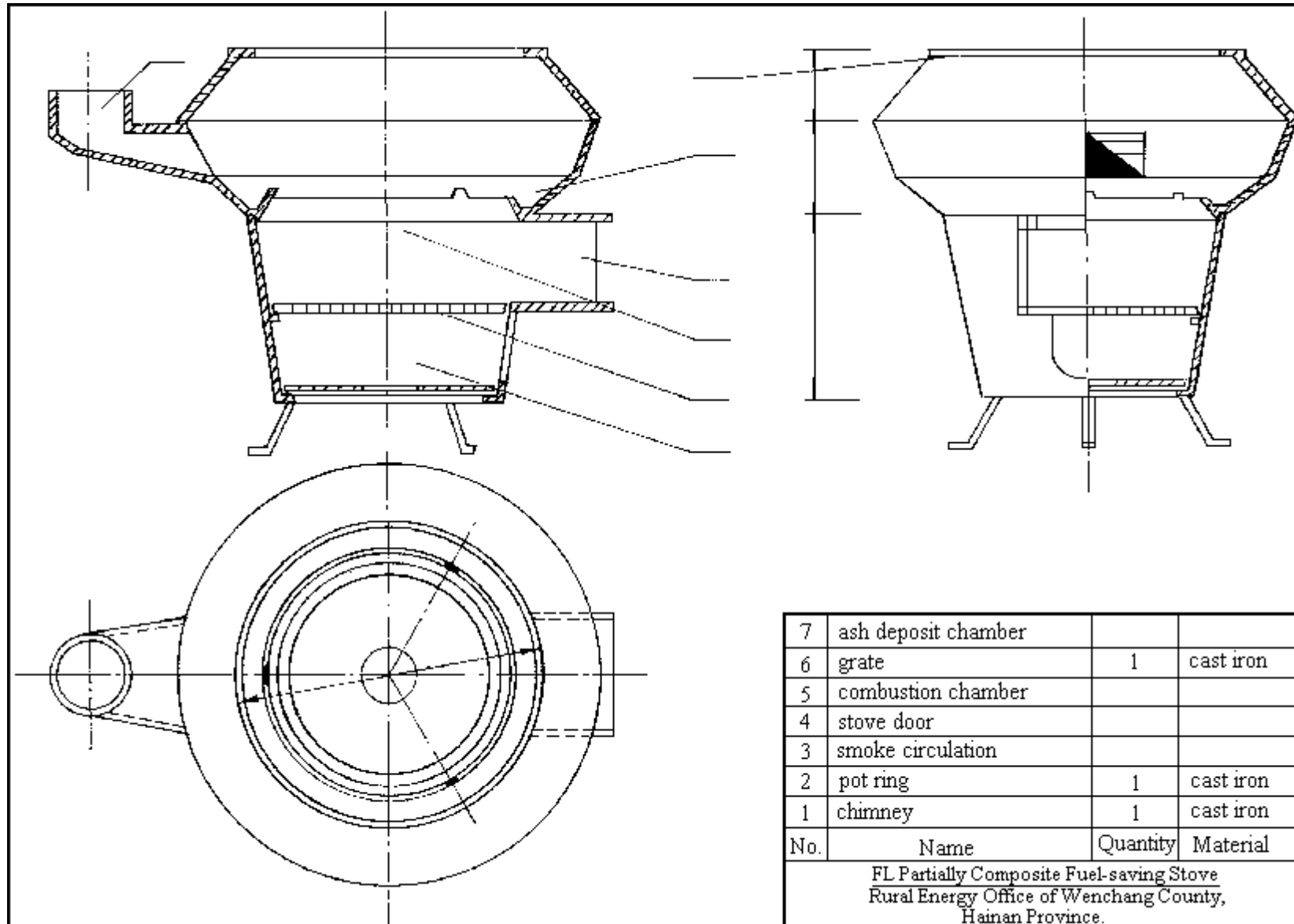

Figure 2.11: Technical drawings of Model FL-CCS

2.3 Model WS Fuel-Saving Composite Stove

The Model WS is a single-pot chimneyed stove developed in 1986 by the Rural Energy Office of Wenshang County, Shandong Province (east-central China). The installation technique is simple and only needs low skilled workers for construction. The concrete slabs can be also mass produced in cement prefabrication centers or plants. As the source of materials for construction is common and the prefabricated components can be easily constructed and moved, it is convenient to promote this stove model. At present, more than 54,000 stoves of this model have been disseminated by the Wenshang County.

Basically, the stove consists of prefabricated concrete slabs made from cement, sand and cobblestone in a ratio of 1:2:4.5 by weight, ie., a stove would need about 20 kg. cement, 40 kg. sand and 90 kg. cobblestones. The stove has 14 concrete components, eg. stove legs, bottom, wall, platform, etc. Its core consists of 4 pieces of arch-shape clay blocks. The stove can be provided with a bellows to ensure complete combustion.

The stove can be fired with a wide range of fuels such as firewood, agri-residues, coal etc. It has many good characteristics, especially a fast temperature rise, high thermal efficiency (40% HU), good thermal insulation as well as stable and reliable quality of construction. The stove costs about RMB 40 Yuan, locally.

The general and main technical features of the Model WS are summarized in table 2.1 and 2.2. **Illustrations and technical drawings** are shown in figures 2.12- 2.13 below.

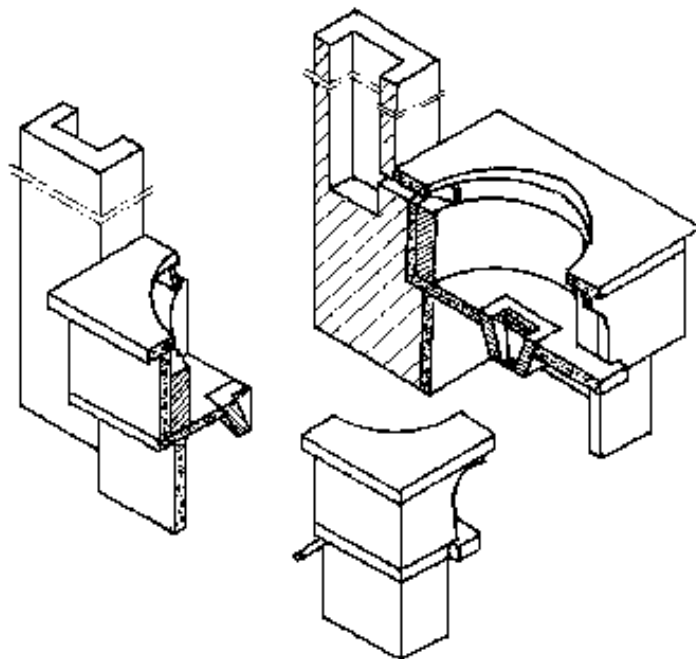

Figure 2.12 a): A perspective view of Model WS Fuel-Saving Composite Stove



Figure 2.12 b): General view of Model WS Fuel-Saving Composite Stove

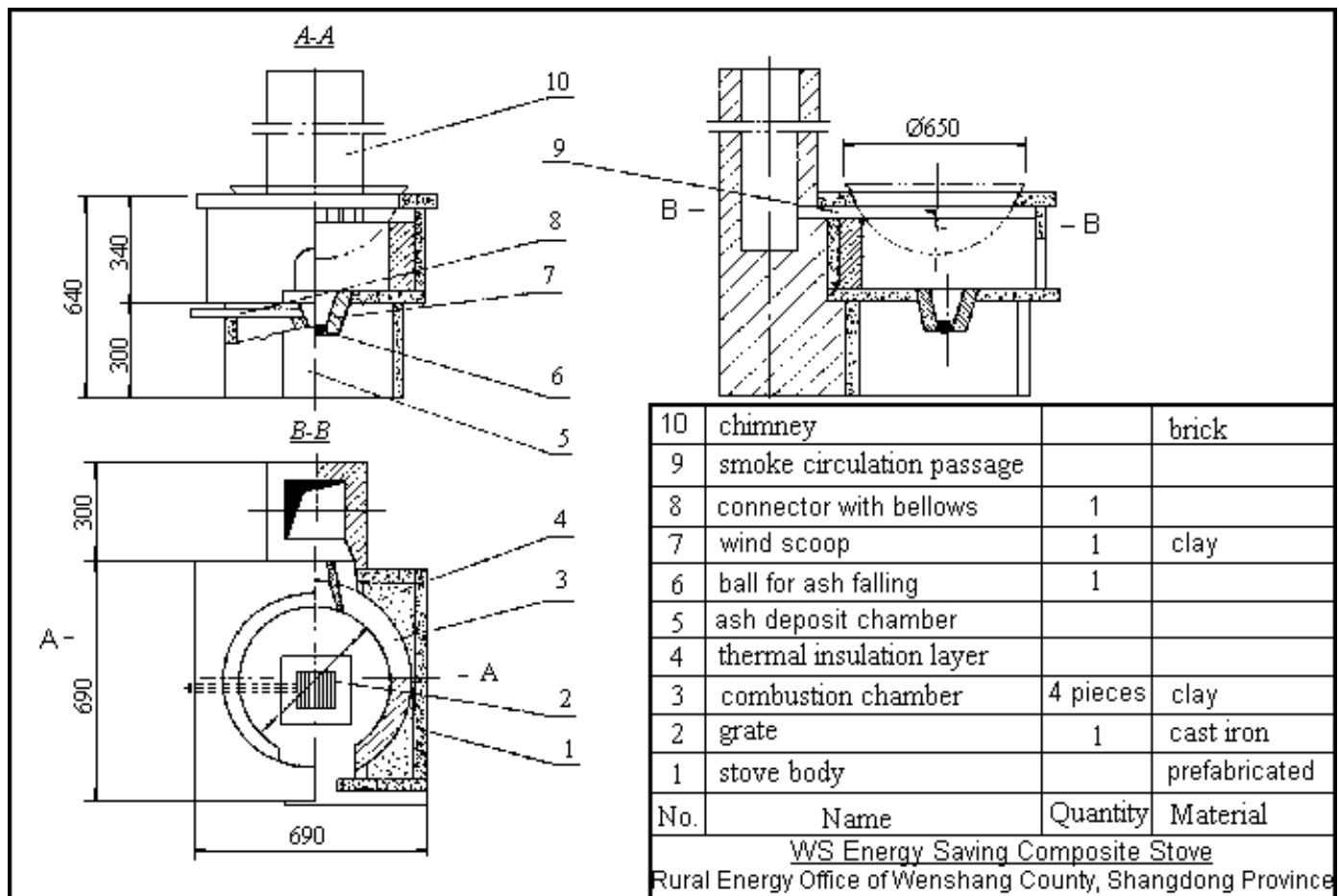

Figure 2.13: Technical Drawings of Model WS Fuel-Saving Composite Stove

2.4 Model YS High-Efficiency Composite Stove

The Model YS high-efficiency composite stove was developed in 1988 by the Rural Energy Office of Yushan County of Jiangxi Province (south-eastern China). The model has two designs: the Model YS-I for loose fuels such as straws, grasses, leaves and agri-residues and the Model YS-II mainly for fuelwood.

Model YS-I is a twin-pot chimneyed stove with a prefabricated combustion chamber, casted from refractory concrete. The grates are arranged in two tiers, the upper and lower (see drawing fig. 2.16). The upper grate is meant for firing with fuelwood. When loose fuels, like grasses and/or leaves are used, the upper tier is removed. The lower tier grate is fixed and made of 3 iron rods of 8-10 mm in diameter. The Model YS-I is designed primarily for farm households. At present, over 20,000 stoves have been disseminated within the county. It has an average heat utilization efficiency of about 35%. The stove can be installed with the prefabricated components on the spot. The total stove cost is about RMB 75 Yuan, locally.

Model YS-II is a single-pot chimneyed stove, equipped with a built-in hot water heating system made of copper to form a water bottle and a circular tube surrounding the combustion chamber and a hot water outlet faucet. The model has ladder-shaped fire reflecting rings in the combustion chamber, an adjustable chimney damper mechanism to control the air draft and to suit the power requirement and a door to control the the combustion and heat loss. The stove consumes about 4.2 kg of firewood for an average size family cooking 3 meals in a day. Its average heat utilization efficiency exceeds 40%. It is very suitable for households living in the town or suburbs. The total stove cost is about RMB 110-130 Yuan.

The general and main technical features of Model YS-I and YS-II are summarized in table 2.1 and 2.2. **Illustrations and technical drawings** are shown in figures 2.14-2.17 below.

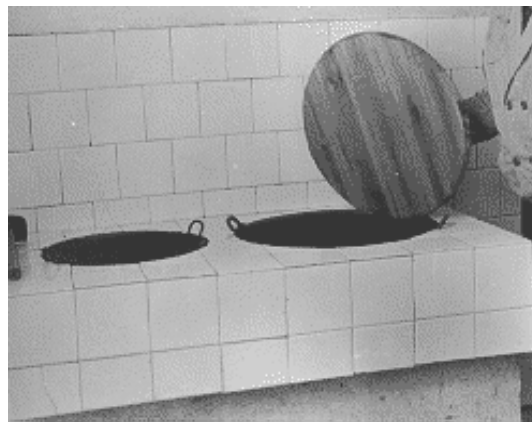
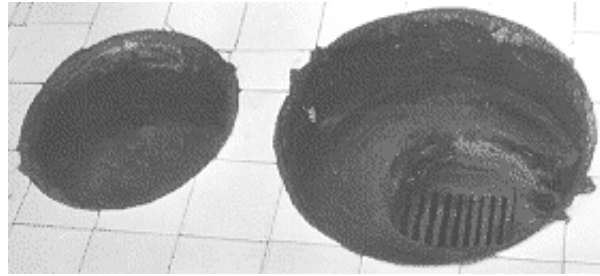
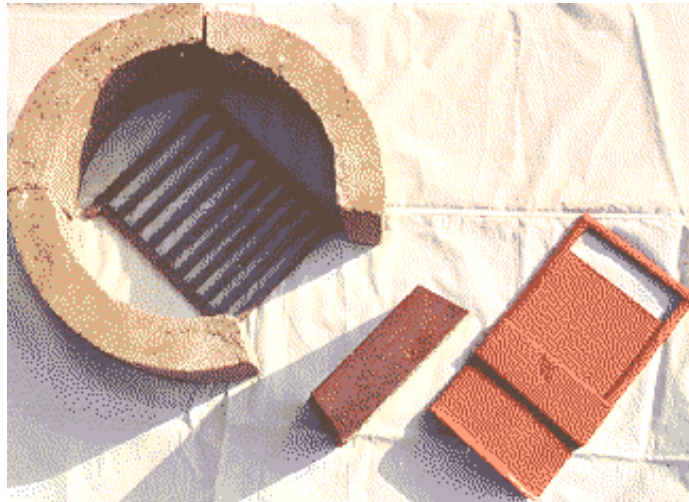

Figure 2.14 a): Model YS-I High-Efficiency Composite Stove showing complete installation



b) Close-up of the combustion chamber



c) Stove parts for combustion chamber, grate and the air inlet door

Figure 2.14 b) and c): Various components of the Model YS-I High Efficiency Composite Stove



a) Complete installation

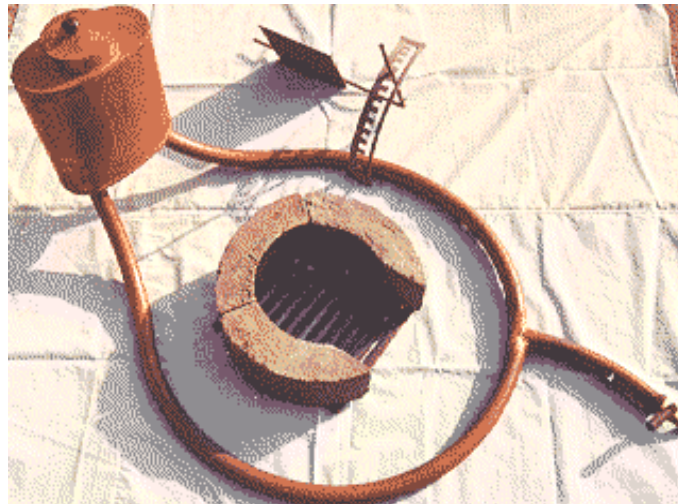

b) Stove parts for combustion chamber, grate, chimney damper with regulator and hot water system

Figure 2.15 a) and b): Various components of Model YS-II High Efficiency Composite

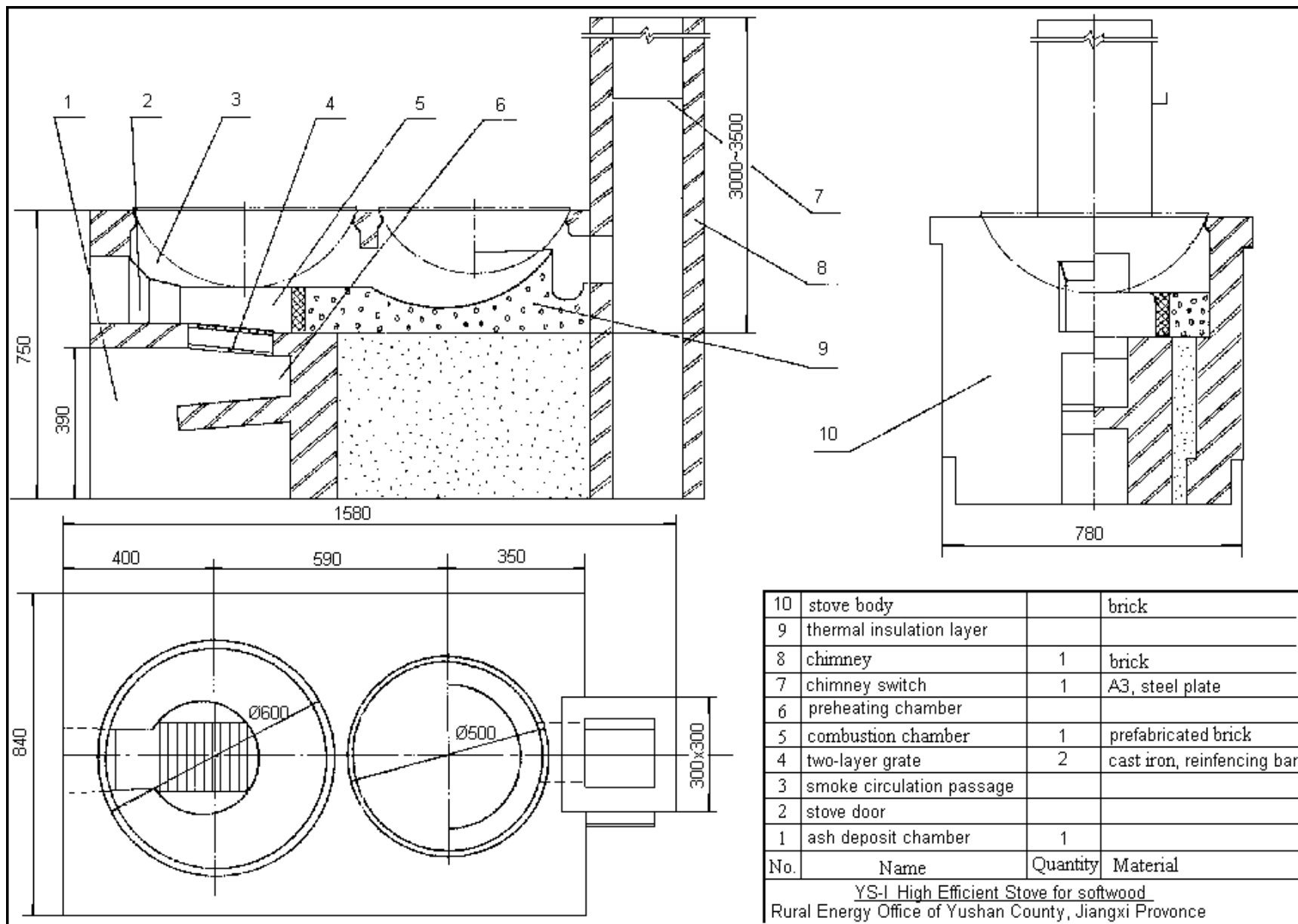

Figure 2.16: Technical drawings of Model YS - I High-Efficiency Composite Stove

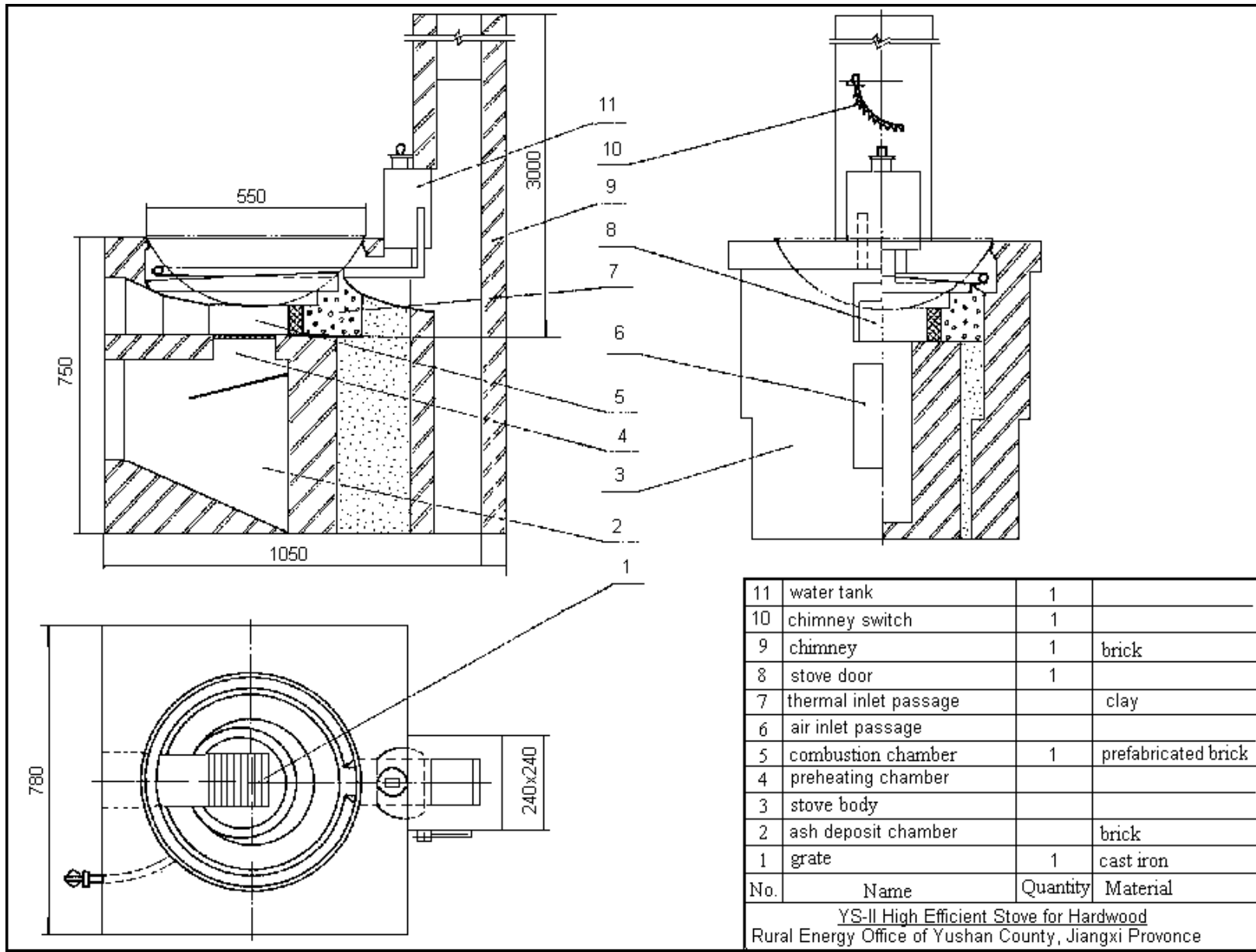

Figure 2.17: Technical drawings of Model YS - II High-Efficiency Composite Stove

2.5 Model Suizhou-400 Commercial Fuel-Saving Stove

The Model Suizhou-400 is a ready-made single-pot chimneyed stove with a hot water system and is commercially available. The model was developed in 1991 by the Rural Energy Institute of Suizhou City, Hubei Province (south-central China). The main purpose of the designer was to overcome the shortcomings, especially the high costs and instability of stoves built *in situ*. The stove's main body and parts are made of steel, copper, ceramic and brick. A skilled worker can make this stove using 2 man-days. The total cost of the stove is about RMB 80 Yuan. At present, over 2,000 sets have been disseminated in Suizhou Prefecture.

The stove can be fired with short pieces of fuelwood and other biomass residues and it can accommodate vessels of 400 mm. in diameter. It needs only 350 grams of firewood, on average, to boil 5 kg of water in 10 minutes and needs about 1.3 kg of agri-residues to cook a meal for a family of 5 members in 35 minutes. The stove has an attractive appearance and can conveniently be moved. It also saves building materials and occupies less space than other common models.

The general and main technical features of the Model Suizhou-400 are summarized in table 2.1 and 2.2. **Illustrations and technical drawings** are shown in figures 2.18-2.20 below.



Figure 2.18 a): General view of Model Suizhou-400 Fuel-Saving Stove



b) Close-up view of the combustion chamber



c) Firing chamber

Figure 2.18 b) and c): Some components of Model Suizhou-400 Fuel-Saving Stove



a) Stove in use

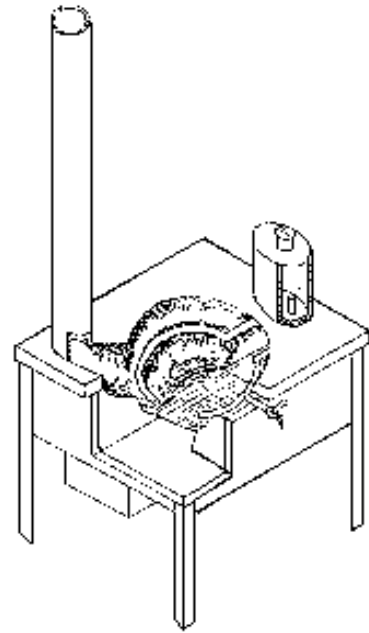

b) Perspective view

Figure 2.19 a) and b): Model Suizhou-400

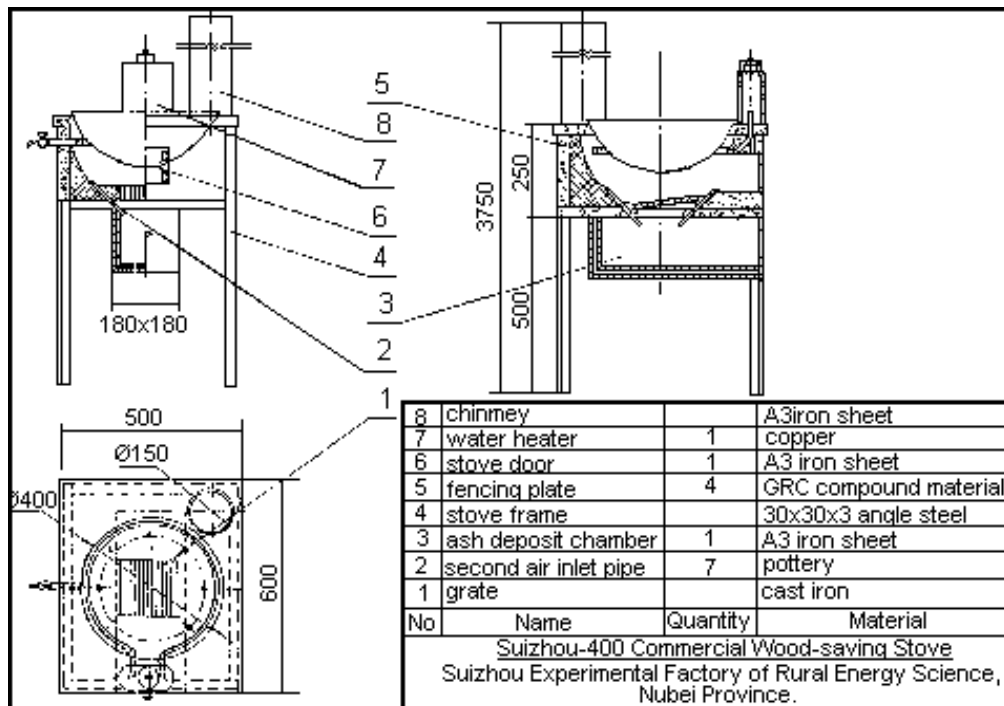

Figure 2.20: Technical drawings of Model Suizhou-400 Fuel-Saving Stove

2.6 Model WH Series Fuel-Efficient Composite Stove

Wuhua County of Guangdong Province, located at the southern tip of China, is a relatively poor area with a large population, little agricultural land, many mountains and few forests. Most farm households use crop residues for fuel fired in hand-made traditional stoves that have a heat utilization efficiency of some 10-15% only. In view of this situation, the Model WH Series fuel-efficient composite stoves were developed in 1989 by CAAERP, Beijing to be used there. The critical parts of the new model such as the fire fencing ring, combustion chamber and grate are prefabricated with cast iron. Depending on income of the farm households and different household requirements, the combustion chamber may be prefabricated with a refractory material. In the series, a stove can be selected to suit specific needs, especially the size of iron cauldrons used in farm households that normally have diameters ranging from 500-750 mm.

Model WH stoves mainly uses rice and wheat straw and/or a combination with other crop residues, weeds etc. Due to scarcity, fuelwood is used only occasionally. The stove consumes about 2.5-3.7 kg. rice straw/hour (with moisture content about 15%). Because of its good performance and durability, the Model WH stoves have been disseminated to over 30,000 households.

A new design of the model WH has cast iron components which are made at very low cost, ie. RMB 2, 2 and 12 Yuan for the fire fencing ring, grate and combustion chamber, respectively. The stove cost, in total, is about RMB 106-126 Yuan, inclusive of prefabricated parts, building materials and workers' wages. The heat utilization efficiency of a single-pot stove can reach about 35-45%. The service life of the main components is over 3 years.

The general and main technical features of the Model WH Series are summarized in table 2.1 and 2.2. **Illustrations and technical drawings** are shown in figures 2.21-2.23 below.

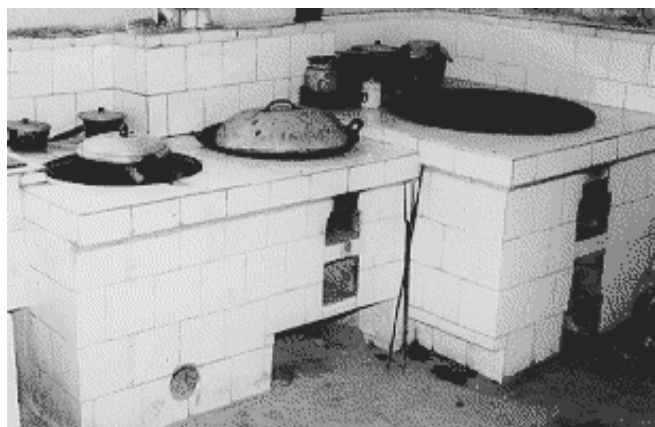
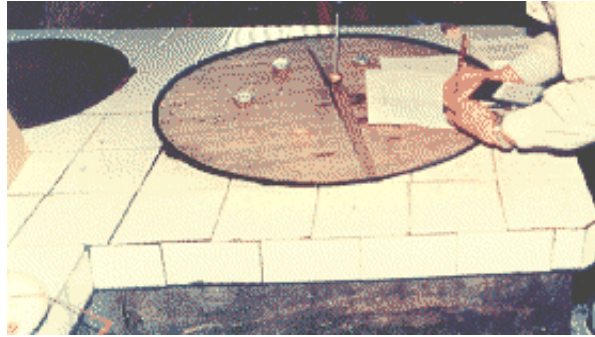

Figure 2.21 a): Model WH Fuel-Efficient Composite Stove (at far right corner)



b) Staff recording test results



c) Construction of Model WH

Figure 2.21 b) and c): Model WH Fuel-Efficient Composite Stove



a) Interior structure of the combustion chamber

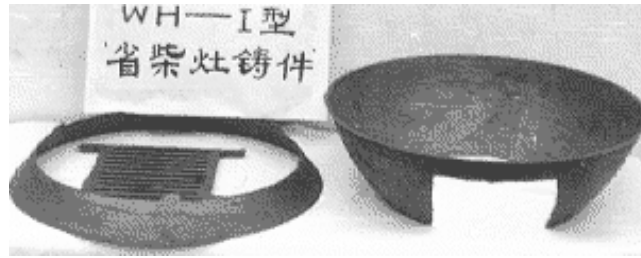

b) Cast iron parts for grate and combustion chamber

Figure 2.22 a) and b): Model WH Fuel-Efficient Composite Stove

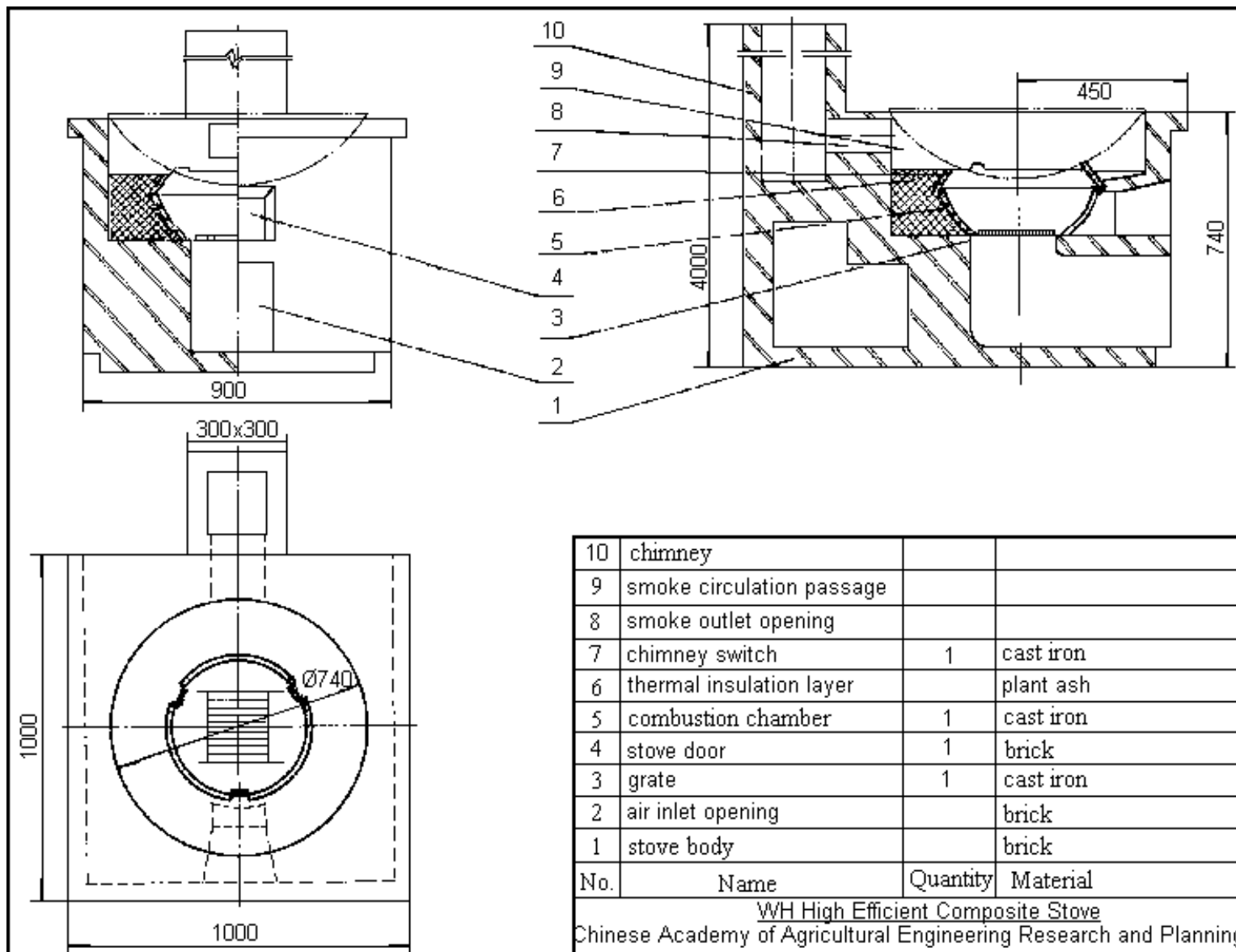

Figure 2.23: Technical drawings of Model WH Fuel-Efficient Composite Stove

2.7 Institutional Coal-Saving Cookstove

The Institutional Coal-Saving Cookstove is a high performance design developed in 1986 by the Rural Energy Office of Dancheng County of Henan Province (central China). The model has fire reflecting rings in multi-steps to enhance the air turbulence during combustion. The stove has good features such as fuel (bituminous coal) and time savings, little heat loss, a concentrated flame and, after igniting, the fire builds-up quickly. The temperature in the combustion chamber can reach 1,200 deg. Celcius.

Because of the rational design of the smoke-exhaust system, the kitchen can be kept clean from coal dust and gas emissions. The heat utilization efficiency of the stove is very high and can reach 50% or over. Tests show that, with 1 kg. of bituminous coal, 28 kg of water can be boiled or can steam 14 kg of Chinese bread. When compared with traditional institutional coal stoves, an average saving of 0.78 kg of coal per person per day is obtained, or equivalent to a saving of some 60% with this new model.

The temperature of the smoke-exhaust is about 183 deg. Celcius containing about 1% of carbon monoxide while the carbon remaining in the slag is about 24%.

This institutional coal stove is very beneficial economically and environmentally. So far more than 1,500 stoves have been adopted in institutional kitchens. The stove costs about RMB 400 Yuan, inclusive of installation.

The general and main technical features of the Model Institution Coal Stove are summarized in table 2.1 and 2.2. **The technical drawings** are shown in figures 2.24 below.

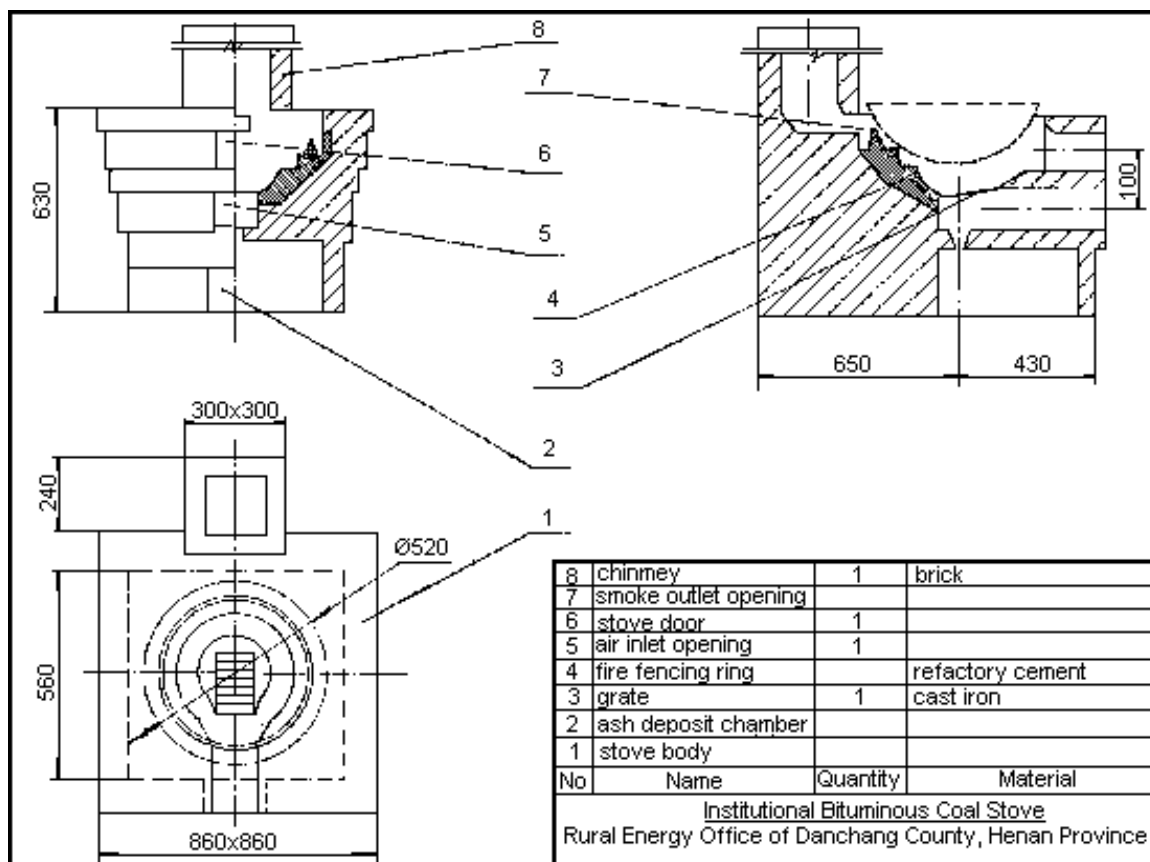

Figure 2.24: Technical Drawings of Institutional Coal-Stove

2.8 Summaries of General and Technical Features of Fuel-Saving Cookstoves

Table 2.1 General Features of Fuel-Saving Cookstoves

Model Year	Inventor	Major fuel type	Shape/size of pan/pot (mm)	Stove cost · RMR yuan	Est. No. disseminated
PT - I PT - II 1988	Rural Energy Office of Pingtan County, Hujian Province. SE-China	firewood agri. res. leaves, etc.	cauldron diam. 600	170-200	10,000
FL/CCS 1990	Energy Conservation Office of Wenchang County, Hainan Prov. S- China	firewood sawdust	cauldron diam. 275	45	10,000
FL/PCS 1987		firewood agri. res.	cylindr. pot or cauldron diam. 350	100	65,000
WS 1986	Rural Energy Office of Wenshang County, Shangdong Province. E-central China	firewood agri. resi. coal	cauldron diam. 560	60	54,000
YS - I 1988	Rural Energy Office of Yushan County, Jiangxi Province. E - central China	firewood agri. resi.	cauldron diam. 540- 660	70-80	70,000
YS - II		firewood	cauldron diam. 400- 540	110-130	15,000
Suizhou- 400 1991	Rural Energy Institute of Suizhou City, Hubei Province, E - central China	firewood agri. resi.	cauldron diam. 400	80	2,000
WH 1989	Chinese Academy of Agri. Engineering Research & Planning, Beijing, China	agri. resi. mostly	cauldron diam. 500- 750	105-126	30,000
ICS 1986	Rural Energy Office of Dancheng County, Henan Province, Central China	bituminous coal	cauldron diam. 520	400	1,500

Note: 5.73 RMB yuan = 1 US\$.
Average wage of a stove construction worker is 5 RMB yuan/day.

Table 2.2 Technical Features of Fuel-Saving Cookstoves

Model Year	Rated power output (kW)	Temperature elevation rate (°C/min)	Vaporization rate (kg/min)	Temperature regaining rate (°C/min)	SFC* (g/min) Fuel type	HU* (%)
PT - I PT - II 1988	4.98 4.72	8.19 10.23	0.163 0.179	1.35 1.35	60.0 Agri.resi.	40.87 38.72
FL/CCS 1990 FL/PCS 1987	2.94 4.56	4.00 6.75	0.095 0.150	0.60 1.25	42.0 Firewood 59.1 Agri.resi.	28.00 37.96
WS 1986	4.96	6.50	0.125	0.72	61.0 Agri.resi.	40.00
YS - I 1988 YS - II 1988	4.22 3.50	10.1 9.8	0.172 0.170	1.29 1.30	59.3 Agri.resi. 35.0 Firewood	35.0 40.0
Suizhou- 400 1991	3.61	7.39	0.35	2.0	36.0 Firewood	40.1
WH 1989	4.49	3.4	0.129	0.47	52.0 Agri.resi.	42.5
ICS 1986	10.51	5.87	0.261	0.80	51.20 Bitum coal	53.44

Note: SFC = Specific fuel consumption
 HU = Heat utilization efficiency
 For test specification, please see explanation in annex 1.

3 SELECTED IMPROVED STOVES FOR COOKING/SPACE HEATING

Most parts of China experience cold weather during the winter months. In rural areas, especially in mountainous regions, the farmers normally adopt the traditional pit-firing for room heating. This practice, besides wasting a great amount of fuelwood, results in harmful emissions such as smoke and other toxic gases. Though space heating stoves of various designs, capacities and fuels are available, they are often not suitable for rural needs and/or affordable. In the following sections, some newly developed space heating stoves are presented. It should be noted that while these models are designed for heating, they can be used for cooking and/or water boiling also.

3.1 Domestic Fuel-Saving Heating Stove

In 1991 the Rural Energy Office of Baokang County of Hubei Province (central China) successfully developed a new design of the domestic heating stove (DHS). The model is very suitable for rural use since it can be used with various fuels, eg. firewood, sawdust, corncob, coal, charcoal etc. Besides being mainly for heating, the stove can be used as a cooking stove.

The main body of the stove is laid by fire-bricks and its major prefabricated parts, ie. grate, combustion chamber, reflecting ring and smoke guard are made with cast iron. The stove costs in total about RMB 65 Yuan.

The DHS has a high thermal efficiency and its rated power output is 3.4 KW. In a room of about 9 square meters, the temperature can be raised from 5 to 19 deg. Celcius in 80 minutes, using 3.4 kg of firewood and at the same time 11.25 kg of water at 5 deg. Celcius can be brought to the boil. After this amount of fuel has been burned completely, two hours later the room temperature remains above 14 deg. Celcius and the residual heat from the stove can raise the temperature of 3.75 kg water in a kettle from 5 to 61 deg. Celcius. The stove has very little smoke emission and hence helps keep the room in a healthy condition. This stove has been warmly welcomed by farm households in Baokang County.

The general and main technical features of the Model Domestic Fuel-Saving Heating Stove are summarized in table 3.1 and 3.2. **Illustrations and technical drawings** are shown in figures 3.1-3.3 below.



a) Complete installation

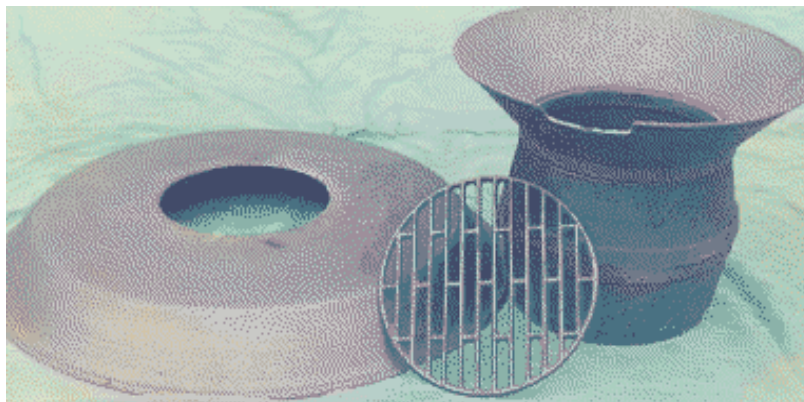

b) Cast iron components

Figure 3.1 a) and b): Domestic Fuel-Saving Heating Stove

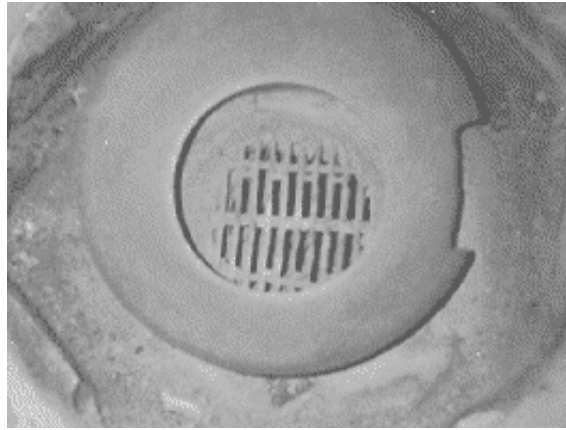

a) Internal structure

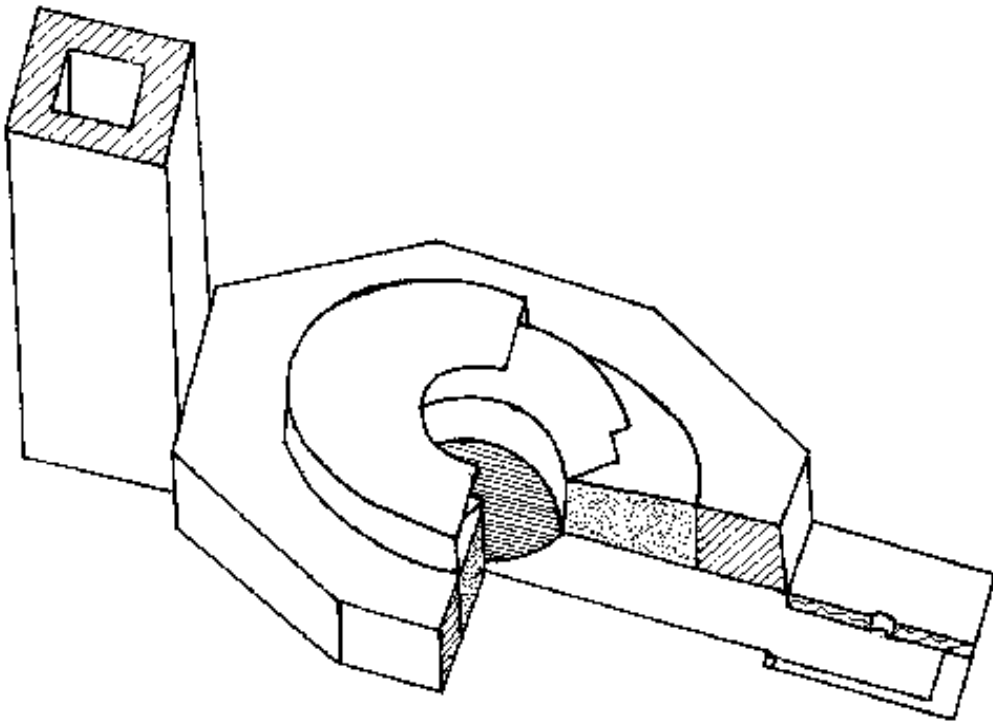

b) Perspective view

Figure 3.2 a) and b): Domestic Fuel-Saving Heating Stove

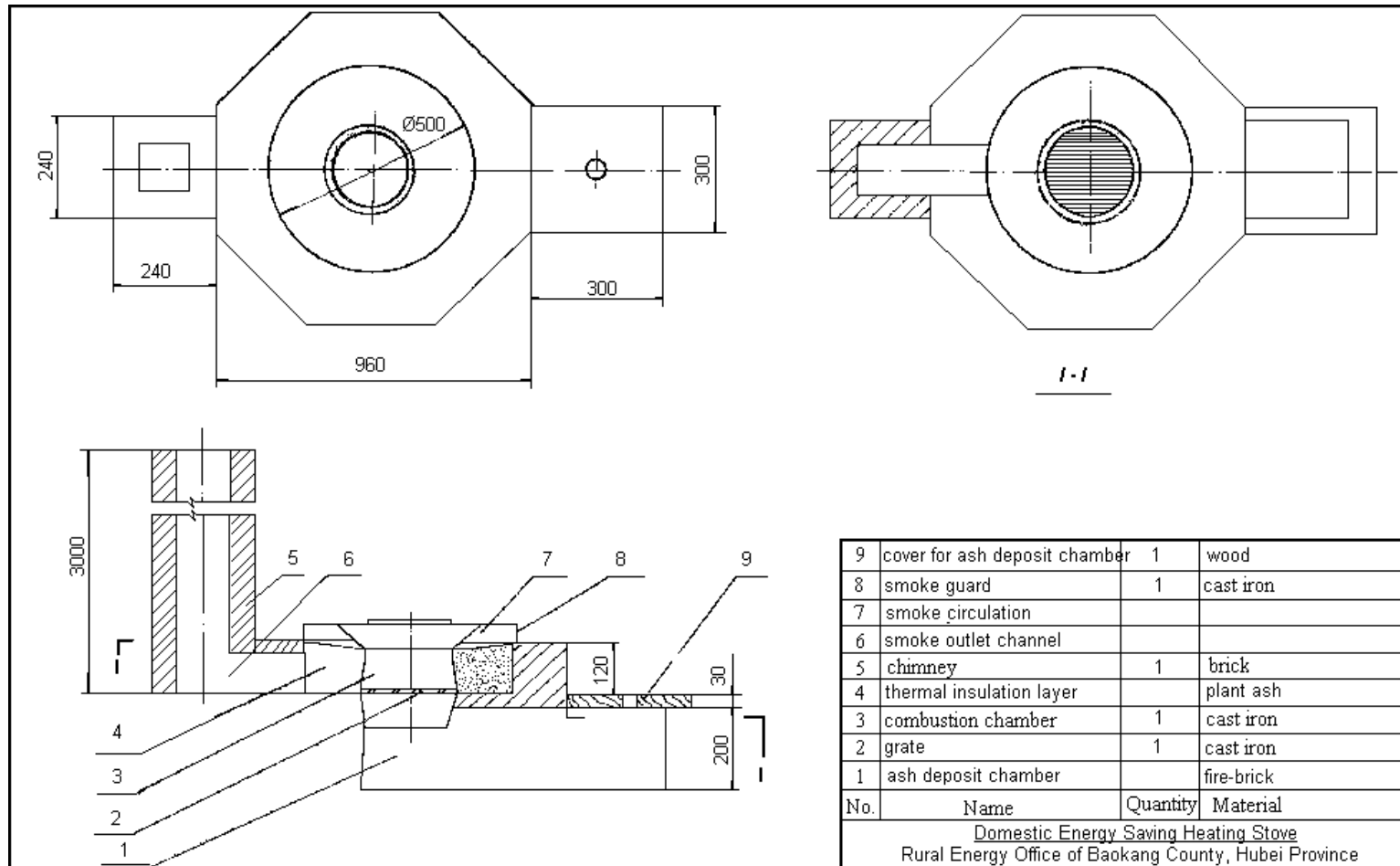

Figure 3.3: Technical drawings of Domestic Fuel-Saving Heating Stove

3.2 Model LX Cooking/Heating Coal Stove

The Model LX cooking/ heating coal stove was developed very recently by the China Center of Rural Energy Research and Training (CCRERT) and is being produced by the Beijing Great Wall Solar Energy Equipment Manufacturing Company. The stove has two functions, namely domestic cooking and space heating. It has a high thermal efficiency, is fuel saving, has a long service life, a high safety standard in operation and is environmentally-friendly.

The stove was developed for use in households in areas where the agricultural-economic conditions are relatively developed but there are no central heating systems. The stove adopts U-shaped heat transferring fins which have a high heat transfer area. The thermal efficiency of the Model LX Series can reach 70%.

The general and main technical features of the Model LX Series Cooking/Heating Coal Stoves are summarized in table 3.1 and 3.2. **Illustrations and technical drawings** are shown in figures 3.4-3.5 below.



a) Outside appearance



b) Close up of the twin-pot model

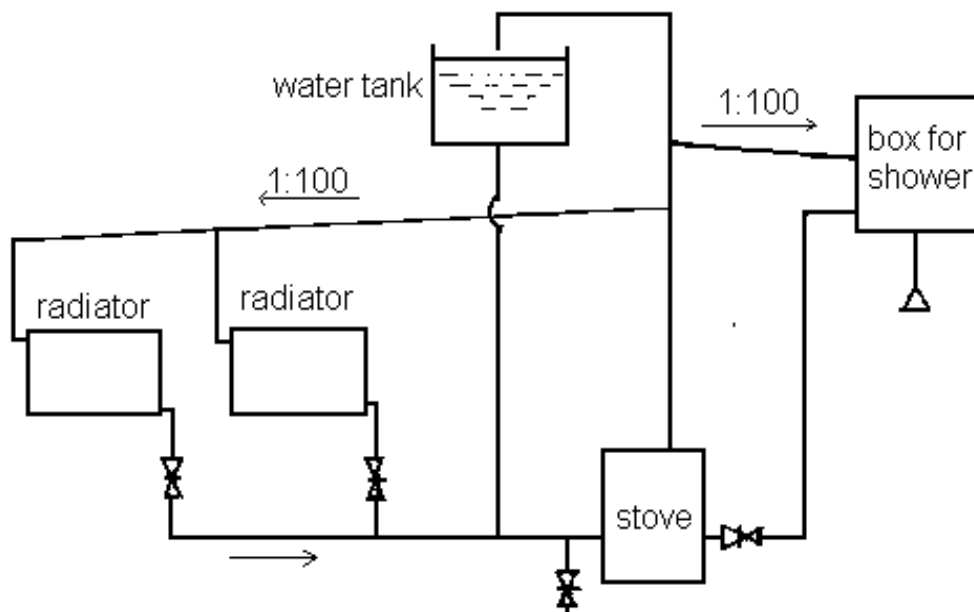

c) Installation diagram for heating and hot shower

Figure 3.4 a), b) and c): Model LX Cooking/Heating Coal Stove

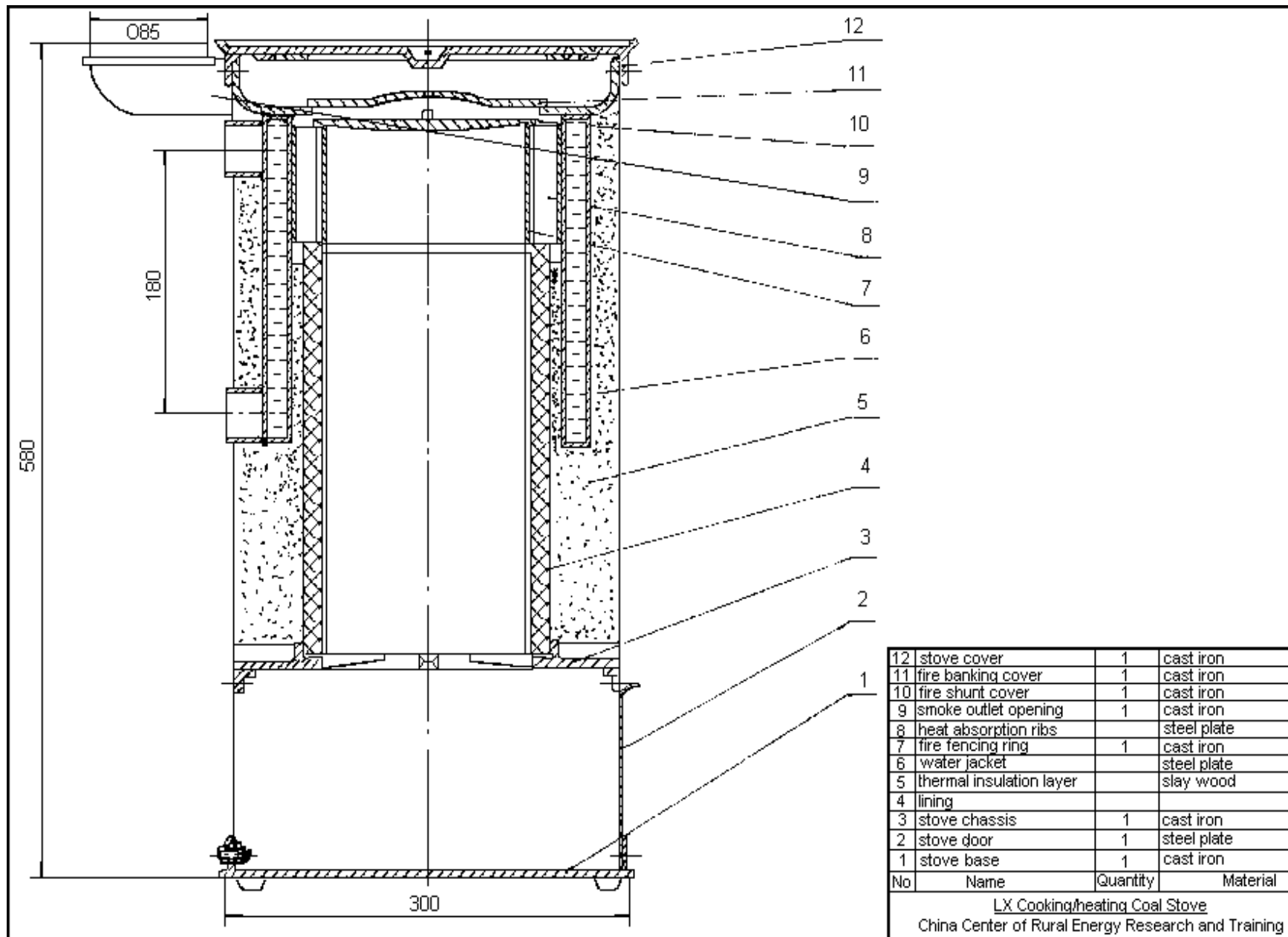

Figure 3.5: Technical drawing of Model LX Single-Pot Cooking/Heating Coal Stove

3.3 Model KSL High-Efficiency Industrial Furnace

The Model KSL high-efficiency industrial furnace was successfully developed by the China Center of Rural Energy Research and Training (CCRERT) in 1989. It is ideal for a wide range of applications, eg. for drying tea, coffee, tobacco etc. as well as for greenhouse heating in the winter.

The Model KSL consists of two vertical combustion chambers. The first chamber is used for gasifying fuelwood and/or biomass briquettes at high temperature, after which the high temperature producer gas enters the second chamber to be burnt continuously. At the bottom of the second chamber, there is an air rationing mechanism to control the supply of air in order to ensure an appropriate air mixing with the producer gas prior to burning. The air extractor and pipe are also assembled to transport the high temperature combustion gas to the necessary places for drying and/or heating applications. Due to very clean combustion of the gas coupled with an installed dust-removing box, food products like tea, coffee etc. can be dried by direct heating.

The Model KSL furnace, at peak operation, can supply heat of 1,500 MJ/h with a thermal efficiency of 75%. The final temperature of the hot gas at the application outlet can be adjusted and brought down to 60-70 deg. Celcius. The furnace has the characteristics of easy ignition/start-up, fast temperature rise, stable heat supply, fuelwood feeding convenience, high degree of safety and reliability as well as a long service life. Besides fuelwood, briquettes of agri-residues can be used as fuel. For wood, the size of wood blocks should be less than 350 x 200 mm. The furnace consumes about 12 kg wood per hour at peak power.

The general and main technical features of the Model KSL furnace are summarized in table 3.1 and 3.2. **The technical drawings** are shown in figure 3.6 below.

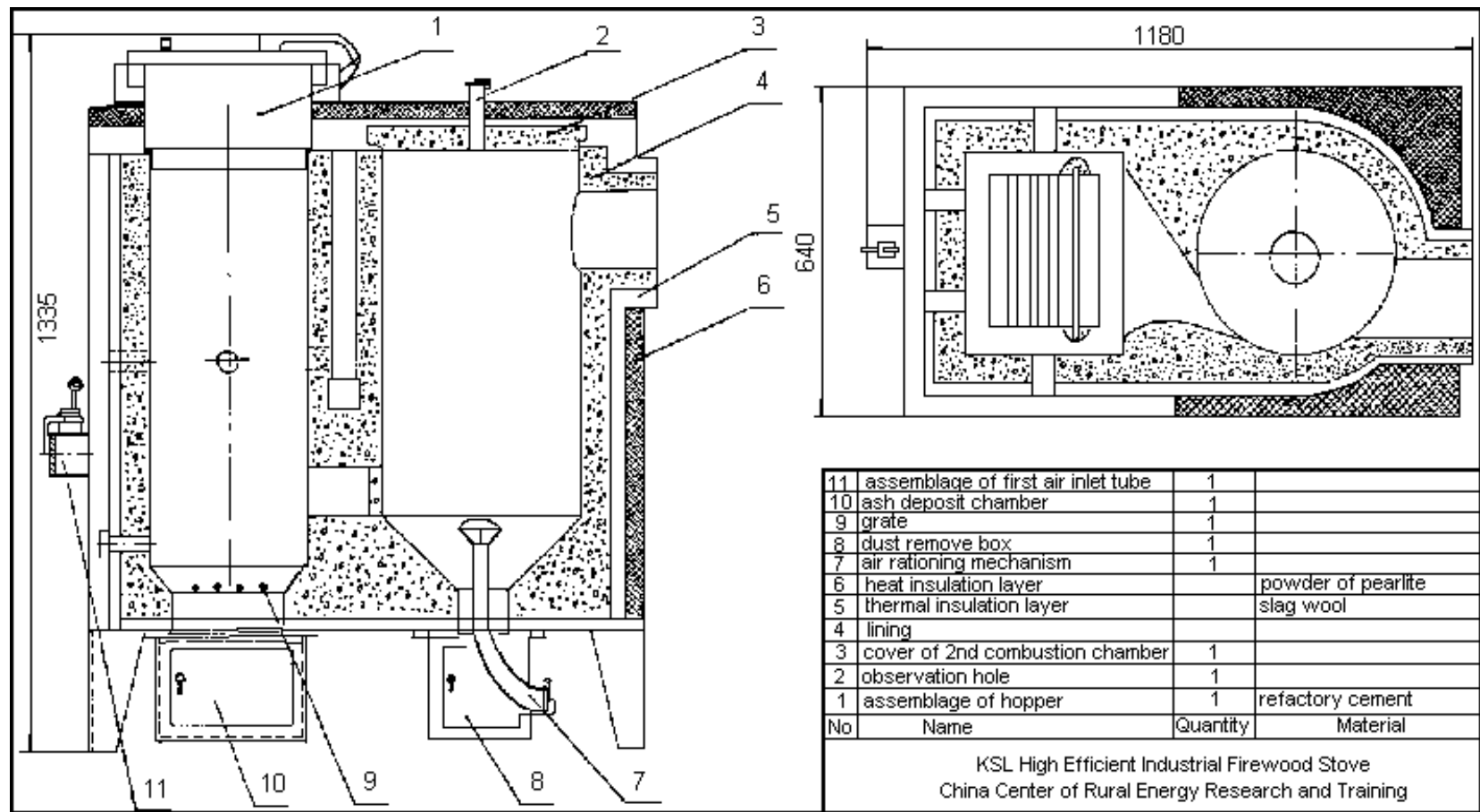

Figure 3.6: Technical drawings of the Model KSL High-Efficiency Industrial Furnace

3.4 Summaries of General and Technical Features of Fuel-Saving Cooking/Heating Stoves

Table 3.1 General Features of Fuel-Saving Cooking/Heating Stoves

Model Year	Inventor	Major fuel type	Shape/size of pan/pot (mm)	Stove cost, RMB yuan	Est. No. disseminated
DHS 1991	Rural Energy Office of Baokang County, Hubei Province, E - Central	firewood, sawdust, corncob, coal	cauldron/pot diam. 300	65	3,000
LXF 40-80 1991 LXS-50 1992	CCRERT, Beijing	coal briquette coal lump	cauldron/pot diam. 300 cauldron/pot diam. 300	300-500 350	1,500 500
KSL 1989	CCRERT, Beijing	firewood, briquette of agri. resi.	-	5,000	50

Note: 5.73 RMB yuan = 1 US\$.

Table 3.2 Technical Features of Fuel-Saving Cooking/Heating Stoves

Model Year	Rated power output (kW)	SFC (g/min) (fuel used)	Heating capacity (square meter)	Thermal efficiency (%)
Cooking/Space Heating				
DHS 1991	3.4	42.5 (firewood, sawdust)	9	32
LXF - 40	4.5	18.4	40	70
LXF - 60	7.0	28.7	60	70
LXF - 80	10.0	40.9	80	70
LXS - 50 1992	5.0	18.6 (coal lump)	50	70
Industrial Heating/Drying				
KSL 1989	37.5	200.0 (firewood, briquette of sawdust and agri.resi.)	-	75

Note: SFC = Specific fuel consumption.

4 CHINA IMPROVED COOKSTOVE ORGANIZATION AND NETWORK

The considerable achievements in research and development activities related to improved cookstoves in China and in the dissemination of the stoves have involved a large number of organizations and manpower including manufacturers, at national, provincial and local levels. As of 1990 there were over 100 research institutes and universities comprising about 1,200 research fellows and 14,000 technicians for the whole of China. Over 5,000 organizations, involving some 29,000 persons, were engaged in administrative and management activities related to stove dissemination. Some 140,000 technicians/field workers participated in stove dissemination and field promotion. There were about 1,400 stove manufactures, involving some 30,000 production workers. This, in total, added up to more than 200,000 persons who took part in improved cookstove development and promotional activities in China.

The information shown in sections 4.1-4.6 below provides an overview of the organizational structure of the stove programme, the national programme management, R & D institutes and universities, provincial and municipal promotion organizations, major stove manufactures and the country's leading experts on stoves.

4.1 National Organization Chart

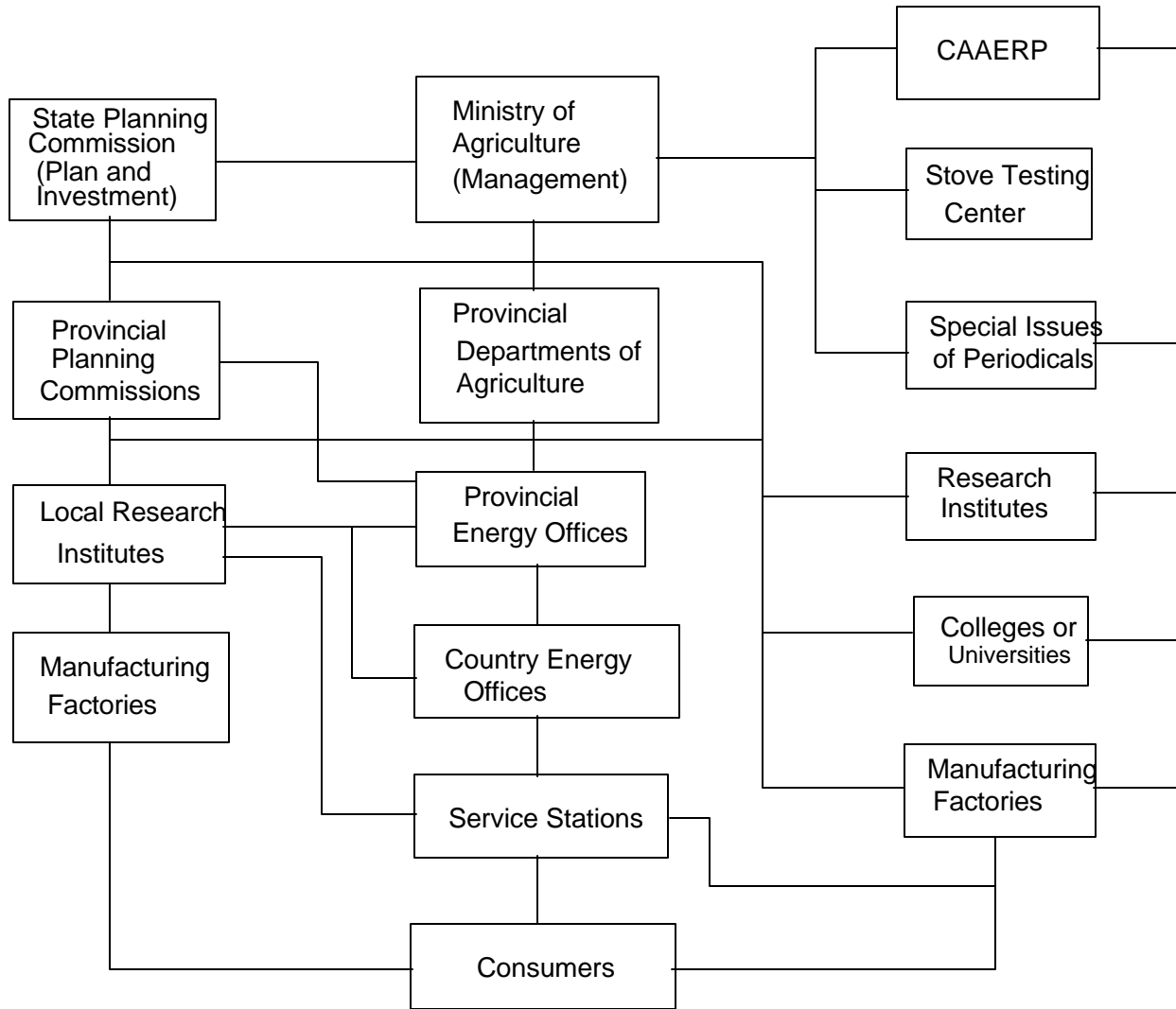

4.2 National Stove Programme Management

- 1) Rural Energy Division, Department of Resources Conservation and Comprehensive Utilization, State Planning Commission (SPC), Beijing.
- 2) Department of Environment Protection and Energy, Ministry of Agriculture (MAGR), Beijing.
- 3) Chinese Academy of Agricultural Engineering Research and Planning (CAAERP), Ministry of Agriculture, Beijing.

4.3 Stove Research and Development Institutes/Universities

- 1) Chinese Academy of Agricultural Engineering Research and Planning.
Add: Agricultural Exhibition Road South, Beijing 100026, China.
Contact person: Mr. Wang Mengjie & Ms. Yao Xiangjun
Fax: 5002448 Tel: 5002616 Tlx: 22233 MAGR CN (CAAERP).
- 2) China Center of Rural energy Research and Training (CCRERT).
Add: Changping, Beijing 102200, China.
Contact person: Mr. Hao Fangzhou
Tel: 9742906
- 3) Henan Agricultural University.
Add: Wenhua Road, Zhengzhou 450002, Henan Province, China.
Contact person: Mr. Zhang Bailiang
Tel: 336173
- 4) Northeast Agricultural College.
Add: Xiangfang District, Harebin, Heilongjing Province, China.
Contact person: Chen Rongyao
- 5) Shanghai Mechanical University.
Add: No. 123 Jungong Road, Shanghai, China.
Contact person: Zhao Zaisan
- 6) China University of Science and Technology.
Add: Nanqilizhan, Jinzhai Road, Hefei, Anhui Province, China.
Contact person: Weng Peidian
- 7) Zhejiang Agricultural University.
Add: No. 105 Kaixuan Road, Hangzhou City, Zhejiang Province, China.
Contact person: Jiang Chengqiu
- 8) Energy Research Institute, Henan Academy of Science.
Add: No. 29 Hanyuan Road, Zhengzhou City, Henan Province, China.
Contact person: Yin Furen

- 9) Heilongjing Institute of Agricultural Machinery Application and Research.
Add: No. 101 Hongxing Road, Suihua City, Heilongjing Province, China.
Contact person: Li Yueren
- 10) Anhui Institute of Agricultural Machinery Research.
Add: No. 1 Huangling Road, Taiyuan City, Shanxi Province, China.
Contact person: Zhao Qixin
- 11) Anhui Institute of Rural Energy Research.
Add: No. 21 Jiushiqiao Road, Hefei City, Anhui Province, China.
Contact person: Tong Youhui
- 12) Rural Energy Institute of Suizhou, Hubei Province
Add: No. 8 Zhanqian Street. Suizhou City, Hubei Province, China.
- 13) Huafeng Fluid Engineering Technology Company of Qinghua University,
Add: Qinghua Road West, Haidian District, Beijing 100083, China.
Contact person: Cai Xuemin
- 14) Beijing Solar Energy Research Institute.
Add: No. 3 Huayuan Road, Haidian District, Beijing 100083, China.
Contact person: Guo Huifen

4.4 Provincial and Municipal Promotional Organization

- 1) Beijing Rural Energy Office.
Add: No. 6 Yaziqiao, Xuanwu District, Beijing 100055, China.
Contact person: Lin Jinyin
Tel: 3266644 - 235, 282
- 2) Rural Energy Office of Hebei Province.
Add: No. 33 Fuqiang Street, Shijiazhuang City, Hebei 050011, China.
Contact person: Luo Qinghua
Tel: 614961
- 3) Agriculture and Environmental Protection Station of Shanxi Province.
Add: No. 50 Yinzejie Street, Taiyuan City, Shanxi 030001, China.
Contact person: Guan Rui
Tel: 442709
- 4) Rural Energy Office of Liaoning Province.
Add: No. 2 Taiyuan Street, Heping District, Shenyang City, Liaoning 110001, China.
Contact person: Gao Shijiang
Tel: 229785, 221259

- 5) Energy and Environment Protection Division, Agricultural Bureau of Jilin.
Add: No. 60 Sidalin Street, Changchun City, Jilin 130051, China.
Contact person: Ye Sen
Tel: 820345
- 6) Rural Energy Office of Helongjiang Province.
Add: No. 204 Zhongshan Road, Harebin City, Helongjiang 150001, China.
Contact person: Zhang Xingjiu
Tel: 220505
- 7) Rural Energy Office of Zhejiang Province.
Add: No. 12 Jiaogong Road, Hangzhou City, Zhejiang 310012, China.
Contact person: Yang Dun
Tel: 883261, 887130
- 8) Rural Energy Office of Anhui Province.
Add: No. 21 Jiushiqiao Road, Hefei City, Anhui 230001, China.
Contact person: Wan Wenping
Tel: 275408
- 9) Rural Energy Office of Hujian Province.
Add: No. 25 Guping Road, Fuzhou City, Fujian 350003, China
Contact person: Zhang Nengying
Tel: 553641
- 10) Rural Energy Office of Jiangxi Province.
Add: Yard of People's Government, Nanchang City, Jiangxi 330046, China.
Contact person: Wan Rensheng
Tel: 225643
- 11) Rural Energy Office of Shangdong Province.
Add: No. 78 Fuqianjie Street, Jinan City, Shandong 250001, China.
Contact person: Liu Wenyong
Tel: 611282
- 12) Rural Energy Office of Hubei Province.
Add: No. 281 Wuluo Road, Wuchang City, Hubei 430070, China.
Contact person: Peng Fuxian
Tel: 714666, 715667
- 13) Rural Energy Office of Guangdong Province.
Add: No. 135 Xianlie Road East, Guangzhou City, Guangdong 510500.
Contact person: Lin Juxong
Tel: 7774312 - office
- 14) Rural Energy & Environmental Protection Station of Hainan Province.
Add: No. 75 Haifu Dadao, Haikou City, Hainan 570003, China.
Contact person: Fu Qing
Tel: 338725

- 15) Rural Energy Office of Sichuan Province.
Add: No. 26 Renmin Road South, Chengdu City, Sichuan 610041, China.
Contact person: Long Dayou
Tel: 582719
- 16) Rural Energy Office of Xinjiang Automonous Region.
Add: No. 171 Shengli Road, Wulumuqi City, Xinjiang 830001, China.
Contact person: Wei Kejian
Tel: 225980

4.5 Major Improved Stove Manufacturers

- 1) Huafeng Fluid Engineering Technology Company of Qinghua University,
Add: Qinghua Road West, Haidian District, Beijing 100083.
- 2) Beijing Solar Energy Research Institute,
Add: No. 3 Huayuan Road, Haidian District, Beijing 100083.
- 3) Energy Equipments Manufacture of Jixian County,
Add: No. 119 Yuyang Road South, Jixian County, Tianjin.
- 4) Energy Equipments Manufacture of Guzhen County,
Add: No. 28 Shengli Road, Guzhen County 233700, Anhui Province.
- 5) Shuangcheng Environment Protection Equipment Factory,
Add: No. 58 Chengguanzhen Road East, Shuangcheng, Heilongjiang Prov.
- 6) Boiler and Heater Equipment Factory, Yingxian County,
Add: Chengdong, Yingxian County, Shanxi Province.
- 7) Shanghai Municipal Xinli Machine Manufacture,
Add: Huqiaozhen, Fengxian County, Shanghai.
- 8) New and Renewable Energy Equipment Manufacture, Fuyang,
Add: No. 147 Jianghui Road, Fuyang City, Anhui Province.
- 9) Energy Saving Products Factory, Jinxian County,
Add: No. 15 Chengguanzhen Road North, Jiangxi Province.
- 10) Huangpi Energy & Environment Protection Company,
Add: No. 1 Xiangyangxin Street, Chengguan, Huangpi County, Hubei Prov.
- 11) Haijun Motor Repair and Assembly Plant, Beijing
Add: Nankou Town, Changping County, Beijing.
- 12) Rural Energy Institute of Suizhou City, Hubei Province
Add: No. 8 Zhanqian Street, Suizhou City, Hubei Province.

- 13) Rural Energy Office of Wenchang County,
Add: No. 131 Guangxi Street, Wenchang County, Hainan Province.
- 14) Rural Energy Office of Wenshang County,
Add: No. 73 Kangfu Road, Wenshang 272501, Shandong Province.

4.6 Leading Experts on Improved Stoves in China

- 1) Wang Mangjie, Deputy Director and Senior Engineer, Chinese Academy of Agricultural Engineering Research and Planning (CAAERP), Beijing.
- 2) Hao Fengzhou, Director and Senior Engineer, China Center of Rural Energy Research and Training (CCRERT), Beijing.
- 3) Yao Xiangjun, Engineer, CAAERP, Beijing.
- 4) Cui Yuanbuo, Senior Engineer, CAAERP, Beijing.
- 5) Li Jingming, Engineer, CAAERP, Beijing.
- 6) Xiao Mingsong, Engineer, CAAERP, Beijing.
- 7) Guo Huifen, Senior Engineer, Beijing Solar Energy Research Institute, Beijing.
- 8) Cai Minxue, Professor, Qinhua University, Beijing.
- 9) Chen Rongyao, Professor, Department of Agricultural Engineering Northeast Agricultural Collage, Harbin, Heilongjing Province.
- 10) Zhao Zaisan, Professor, Dynamic Engineering College, Shanghai Mechanical University, Shanghai.
- 11) Weng Peidian, Professor, Department of Mechanical Engineering, China University of Science and Technology, Hefei, Anhui Province.
- 12) Zhang Bailinag, Director and Professor, Henan Agricultural College, Henan Province.
- 13) Su Xianwu, Senior Engineer, Beijing Testing Institute of Pressure Boiler, Beijing.
- 14) Cai Changda, Senior Engineer, Hangzhou Rural Energy Office, Zhejiang Province.
- 15) Tu Yunzhan, Chief and Senior Engineer, Bureau of Energy and Environment Protection, Ministry of Agriculture.

- 16) Li Kelun, Senior Engineer, Rural Energy Office of Sichuan Province, Chengdu, Sichuan Province.
- 17) Jin Zongwu, Shanghai Agricultural Department, Shanghai.
- 18) Zhou Chongjie, Professor, Liuzhou Normal School of Guangxi Autonomous Region, Liuzhou, Guangxi Autonomous Region.
- 19) Chen Huixiong, Engineer, Rural Energy Office of Pingtan County, Fujian Province.
- 20) Xu Qiguo, Engineer, Rural Energy Office of Baokang County, Hubei Province.
- 21) Li Zhian, Engineer, Rural Energy Office of Dancheng County, Henan Province.
- 22) Fu Yongcheng, Engineer, Energy Conservation Office of Wenchang County, Hainan Province.
- 23) Xu Wen, Engineer, Rural Energy Office of Wenshang County, Shandong Province.
- 24) Chen Jiabin, Engineer, Rural Energy Institute of Suizhou City, Hubei Province.
- 25) Liu Renli, Engineer, Rural Energy Office of Qianyang County, Hunan Province.
- 26) Shen Mengsheng, Senior Engineer, Biomass Office of Sichuan Province.

5 REFERENCES

- 1) Gu Shuhua & Chen Rongyao. 1992. Technical and Economic Evaluation on Efficient Firewood Stove Dissemination in China. Beijing Press of Science and Technology.
- 2) State Standard of the People's Republic of China on Testing Method for Domestic Firewood Stove, GB 4363-84. China Standard Press, Oct. 1984.
- 3) Draft Standard of the People's Republic of China on Testing Method for Domestic Cooking/Heating Coal Stove.
- 4) Long Dayou. 1987. Development Tendency and Countermeasure of Firewood/Coal Saving Stove. Publication of Third National Workshop on Rural Energy.
- 5) Chinese Fuel Saving Stoves. 1986. RAPA Publication 1986/25. FAO Regional Office for Asia and the Pacific. Bangkok.

Annex 1

State Standard of the People's Republic of China Testing Method for the Heat Properties of Civil Firewood Stoves

The method is applicable for the heat properties testing of single-pot or multi-pot stoves fueled by firewood (firewood, crop stalks, tree leaves, etc.).

1. Brief description of the method

The heat properties coefficient is determined through the temperature elevation and vaporization in a water boiling test by combusting firewood of given amount and quality to heat water of given amount in a pot.

2. Heat properties coefficient

- 2.1 Heat efficiency refers to the ratio of total of the heat (over heat) absorbed by water in the pot during the process of temperature elevation and the heat (latent heat) absorbed by the water vaporized to the heat of firewood combusted in the stove. The ratio reflects the percent of heat utilized by the stove.
- 2.2 Temperature elevation rate - Elevation of temperature in a unit time. It reflects the starting performance of a stove.
- 2.3 Vaporization rate - The amount of water in the pot evaporated in a unit time. It reflects the starting performance of a stove.
- 2.4 Temperature regaining rate - Regaining of temperature of water in the pot. It shows a stove's performance on heat insulation and heat storage.

Note: Total heat absorbed by all pots should be taken into calculation when determining the heat efficiency of a multi-pot stove (including stoves with heat recovery system). But only should the main pot be taken into account when determining temperature elevation rate, vaporization rate and temperature regaining rate of a multi-pot stove.

3. Instrumentation for testing

a thermometer with a measuring range of 0-100°C and graduated in 0.5°C.

a clock with error per day less than 2 minutes.

a platform scale with a measuring range of 0-10 kg and minimum sensing weight of 5 g.

a psychrometer

4. Testing conditions

ambient temperature: 10-30°C

relative humidity: less than 85 percent

testing medium: water at normal atmospheric temperature

fuel used in the test: air-dried firewood

As a group of stoves are tested, the space between stoves should be larger than 1.5 m, and all stoves being tested should face the same direction.

5. Testing procedure

- 5.1 The lower calorific value, $Q_D^Y_w$ (kcal/kg) is determined.
- 5.2 There should be a port at the centre of the pot cover for installing the thermometer and, 6 exhaust ports evenly scattered concentrically at 1/2 radius of the pot cover. Total space of the ports is about 1 percent of that of the pot cover.
- 5.3 Volume of the pot G_G (kg) for containing water is determined.
- 5.4 The water G_{s_1} (kg), equivalent to 2/3 of G_G , is put into the pot.
- 5.5 The amount of firewood for testing is determined. Its weight should be 1/7-1/5 of the water weight G_{s_1} (kg) (depending on the lower calorific value of the fuel used).
- 5.6 The pot is covered with the pot cover. The thermometer is fit in the central port. The space between the thermometer bulb and the bottom of the pot is about 3 cm.
- 5.7 The beginning temperature of the water in pot t_1 (°C), ambient temperature t_a (°C) and relative humidity (%) are measured and recorded.
- 5.8 Start to set the fire. The very time when the fire is set is recorded as T_1 (hour : minute)
- 5.9 The very time T_2 when the water in pot reaches the local boiling point t_2 (°C) is recorded.
- 5.10 The fire is kept through continuously supplying firewood to heat the water to vaporize until the given firewood is used up.
- 5.11 The very time T_3 (hour : minute) when the temperature of the water in pot deviates from the boiling point is closely noted and recorded.

- 5.12 The pot cover is quickly removed and the remaining water in the pot is removed and weighed G_{S_3} (kg). The water which has been prepared in advance at the weight of $1/2G_{S_1}$ and at normal atmospheric temperature t'_3 ($^{\circ}\text{C}$) is put into the pot. Then the pot is covered again.
- 5.13 20 minutes later, the regaining temperature of the water in pot is recorded t'_4 ($^{\circ}\text{C}$)
- 5.14 Clear the testing spot.
- 5.15 Repeat the test twice after the stove cools down to normal temperature.

6. Calculation and process of testing results

6.1 Fill in data form
 During the process of the test, all data should be taken down in the data form (Table-1) at very time when they are obtained.

6.2 Formula for calculation

6.2.1 Temperature elevation rate

$$V_1 = \frac{t_2 - t_1}{T_2 - T_1} \text{ (}^{\circ}\text{C/min)} \dots\dots\dots (1)$$

in the formula

- t_1 --- beginning temperature of the water in pot ($^{\circ}\text{C}$)
- t_2 --- temperature at boiling point ($^{\circ}\text{C}$)
- T_1 --- the time when the fire in the stove is set (hour : minute)
- T_2 --- the time when temperature of the water in pot reaches the boiling point (hour : minute).

6.2.2 Vaporization rate

$$V_2 = \frac{G_{S_2} - G_{S_3}}{T_3 - T_2} \text{ (kg/minute)} \dots\dots\dots (2)$$

in the formula

- G_{S_2} --- water weight when reaching boiling point (kg)
- G_{S_3} --- water weight when deviating from boiling point (kg)
- Water weight G_{S_1} be taken as G_{S_2}
- T_3 --- the time when water temperature in pot deviates from boiling point (hour : minute)

6.2.3 Temperature regaining rate

$$V_3 = \frac{t'_4 - t'_3}{T_4 - T_3} \quad (\text{°C/minute}) \dots\dots\dots (3)$$

in the formula

t'_3 --- beginning temperature of water in pot for regaining temperature test (°C)

t'_4 --- peak temperature of water in pot for regaining temperature (°C)

T_4 --- the time when the test ends and, $T_4 - T_3 = 20$ minutes

6.2.4 Heat efficiency

$$= \frac{G_{s1} C_p (t_2 - t_1) + \tau (G_{s2} - G_{s3})}{G_c Q_D^Y W} \times 100 (\%) \dots\dots\dots (4)$$

in the formula

C_p --- heat capacity of water at normal atmospheric pressure

C_p may equals 1 kcal/kg

τ --- latent heat of vaporization at boiling point

G_c --- firewood weight (kg)

$Q_D^Y W$ --- lower calorific value of firewood (kcal/kg)

τ values may be seen as below:

boiling point temperature, t (°C)	86	88	90	92	94	96	98	100
latent heat of vaporization, τ (kcal/kg)	547.7	546.4	545.2	543.9	542.7	541.5	540.3	539.0

for multi-pot stoves, the formula is

$$\frac{\sum_{i=1}^n G_{s1i} C_p (t_{2i} - t_{1i}) + \sum_{i=1}^n \tau (G_{s2i} - G_{s3i})}{G_c Q_D^Y W} \times 100 (\%) \dots\dots\dots (5)$$

in the formula

G_{s1i} , t_{1i} , t_{2i} , G_{s2i} , G_{s3i} --- corresponding value for pot i ;

n --- total number of pots,

6.3 Data processing

6.3.1 Calculation of coefficient

Each coefficient is calculated with the formulas and data obtained. In three calculations, arithmetic mean is taken, V_1, V_2, V_3 , and comparison is made with corresponding coefficient value. The error should be within error allowance.

6.3.2 Error allowance

The absolute value for absolute error of heat utilization efficiency should be less than or equal to 3.

6.3.3 Describing curves

Testing results may also be expressed in form of curves as seen below.

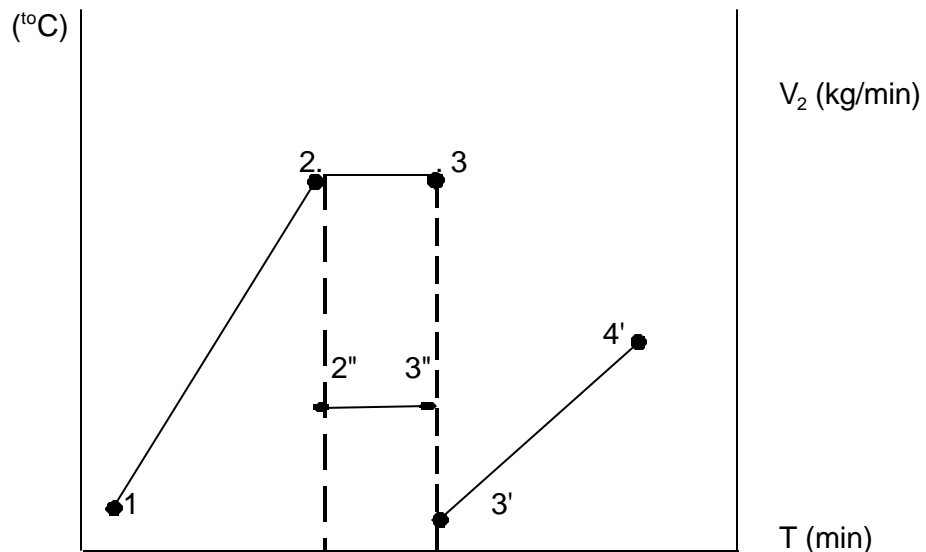

Testing of stove for thermal characteristics

In above figure, the abscissa T represents time, the ordinate t refers to the temperature of the water in pot and V_2 indicates the vaporization rate.

Line 1-2 shows the rate of temperature elevation. A steep slope of the line means a quick temperature elevation of water. Line 2'' - 3'' shows the performance vaporization. Long vertical section of the line indicates a strong vaporization during the test.

Line 3' - 4' shows the performance of heat insulation and heat storage of stoves. A steep slope of the line means the stove performs well in heat insulation and storage, i.e. high temperature regaining rate.

7. Test report

Title of stoves, type, producer, building materials, stove structure, testing conditions, testing results, date of test, place of test, operators, persons in charge, etc. should be noted in the report as shown in the data form below.

DATA RECORDING FORM	
name of stoves
date
time T (hour : minute)
interval ΔT (minute)
water temperature:	instantaneous t_s ($^{\circ}\text{C}$)
	difference in temperature Δt_s ($^{\circ}\text{C}$)
water weight:	at the beginning G_{s_1} (kg)
	remain G_{s_3} (kg)
	vaporized ΔG_s (kg)
weight of	
firewood G_c (kg)
low order calorific capacity Q_D^Y (kcal/kg)
Ambient temperature t_a ($^{\circ}\text{C}$)
relative humidity (%)
	temperature elevation rate v_1 ($^{\circ}\text{C}/\text{min}$)
results of	vaporization rate v_2 (kg/min)
calculation	temperature regaining rate v_3 ($^{\circ}\text{C}/\text{min}$)
	heat utilization efficiency (%)
remarks:	
	tester.....

Remarks:

This standard is put forward by Ministry of Agriculture, Animal Husbandry and Fishery.
 This standard is within the responsibility of Chinese Academy of Agricultural Engineering Research and Planning.
 Chinese Academy of Agricultural Engineering Research and Planning is in charge of the drafting of the standard.
 The standard is co-drafted by Cui Yuanbo and Chen Jing.
 The standard is first issued in 1984.

Annex 2

Relationship between lower calorific value and the moisture content of biomass fuels often used in China

units: MJ/Kg.

Type	Moisture content								
	5	7	9	11	14	16	18	20	22
maize stalk	15.4	15.4	14.7	14.3	13.7	13.3	12.9	12.6	12.2
sorghum stalk	15.7	15.4	15.0	14.6	14.0	13.6	13.2	12.8	12.5
cotton stalk	15.9	15.6	15.2	14.8	14.2	13.8	13.4	13.0	12.6
beans straw	15.7	15.3	14.9	14.6	14.0	13.6	13.2	12.8	12.5
wheat straw	15.4	15.1	14.7	14.3	13.7	13.4	13.0	12.6	12.2
rice straw	14.2	13.8	13.6	13.1	12.6	12.3	11.9	11.5	11.3
millet straw	14.8	14.4	14.1	13.7	13.1	12.8	12.5	12.1	11.7
poplar branch	14.0	13.6	13.3	12.9	12.4	12.0	11.7	11.4	11.0
cattle manure	15.4	15.0	14.6	14.2	13.6	13.3	12.9	11.7	12.1
masson pine	18.4	17.9	17.5	17.1	16.4	15.9	15.5	15.1	14.6
birch wood	16.9	16.5	16.1	15.7	15.1	14.7	14.3	13.9	13.5