

PRODUCER GAS STOVE USING NATURAL DRAFT

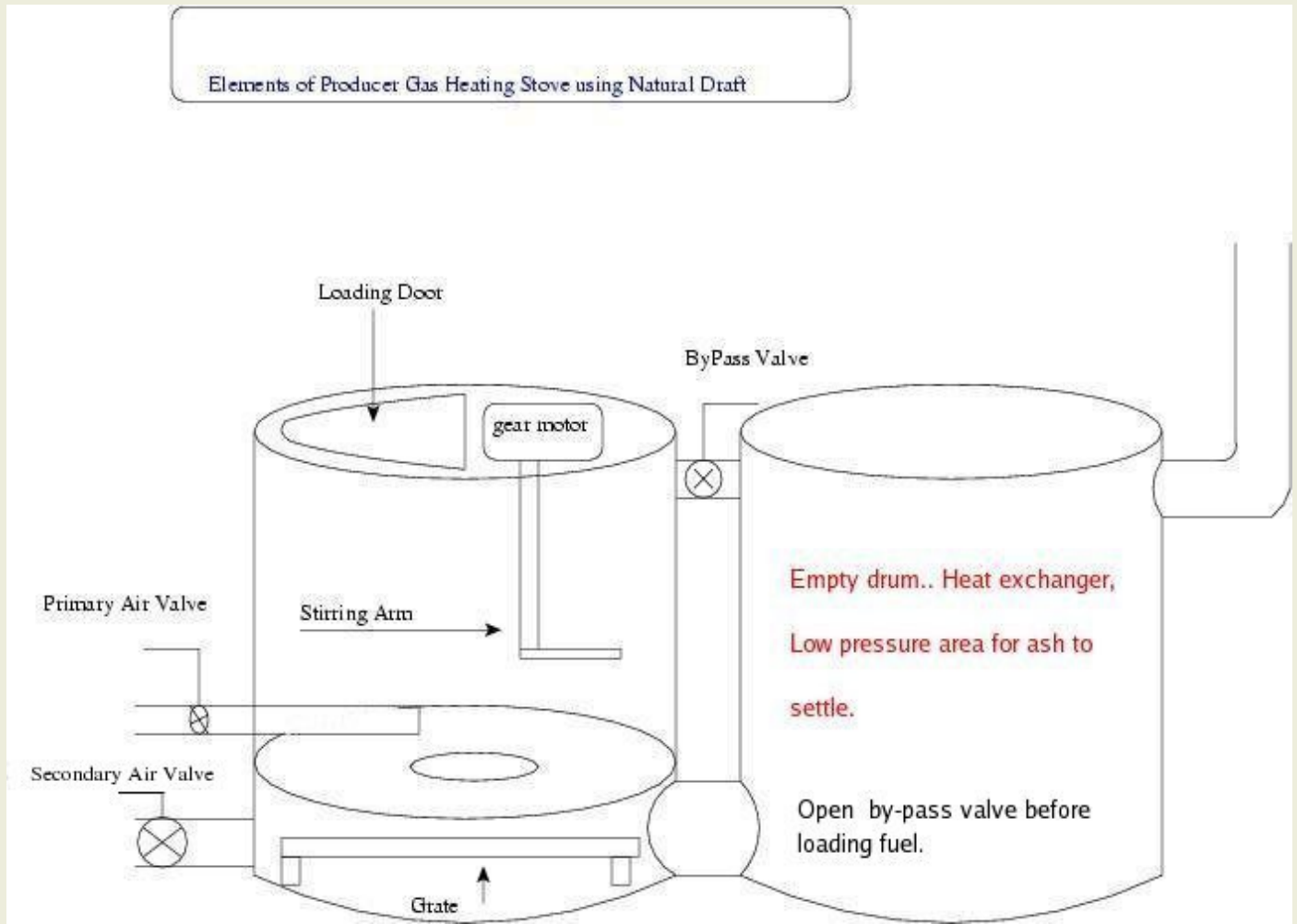

I've got the stove to the point where it is working fairly well. It starts right up by burning a bunch of newspaper under the grate to create the draft needed to get the fire in the upper pyrolysis chamber going. After about 10 minutes the smoke goes away and it will burn with little or no trace of smoke till it gets to the end of the burn. When it gets to the charcoal burning stage it gives off a light grey smoke. At this time it's best to shut all the air inlets down and save what charcoal is in there for the next start up.

Many burn tests and changes have brought us to where we are now. I have not been able to get the fuel to feed consistantly and I am using a gear motor to stir the wood and keep it from "bridging." It took two weeks of spare time to get the interval timer done. It is still on the prototype board. The interval timer turns the gear motor ON for a few seconds about every six minutes. The two "pots" control the time between intervals and also the time that the stirring motor is operating. The stirring action keeps the fuel from "bridging" and keeps the area of hot coals in the lower chamber full. I will post a circuit diagram when I have a little more time.

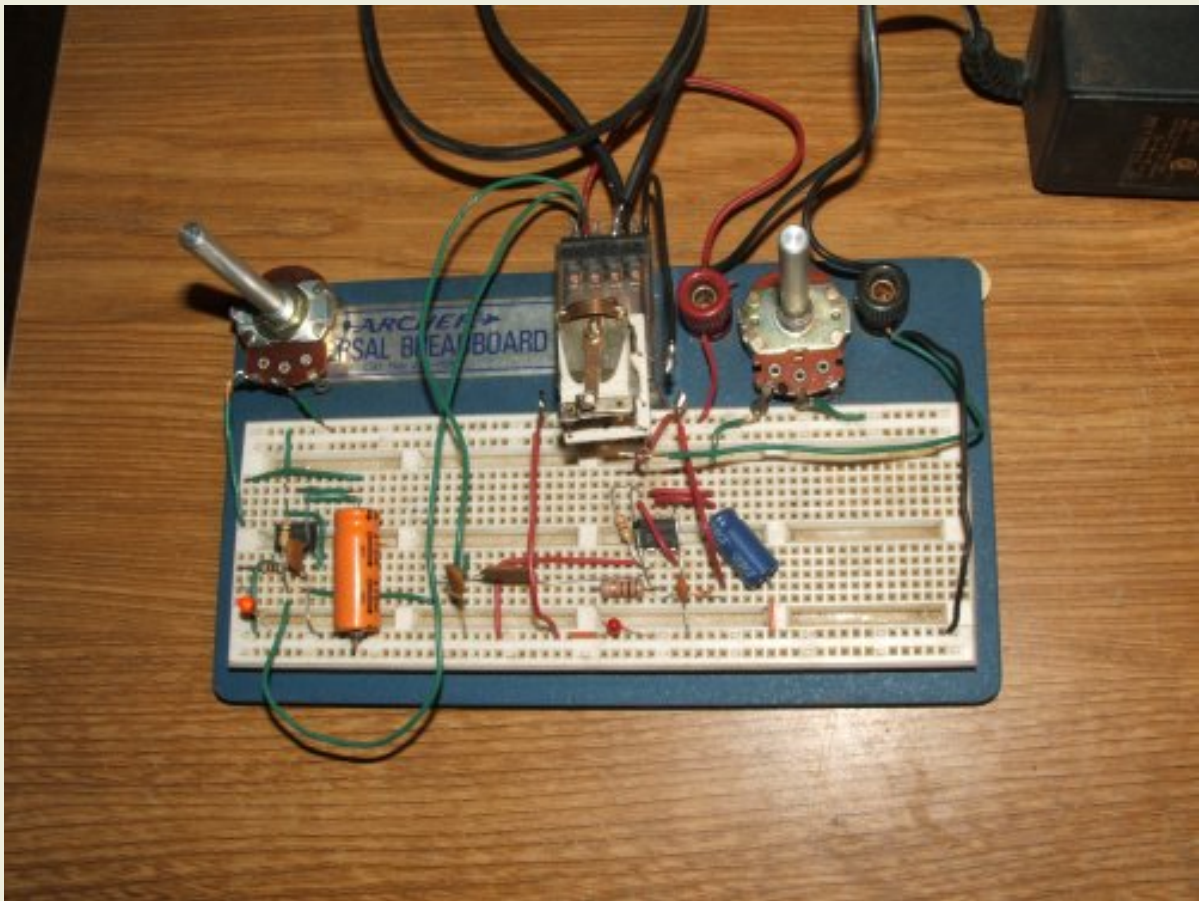

The stove is made of two fifty gallon drums. The only critical dimensions are the size of the opening in the restrictor plate and the length of the reactor tube and the distance between the end of the tube and the top of the grate surface. The second drum is mostly a heat exchanger.

I guess that a thrifty guy could build this thing for about \$300.00 even if he bought the drums new. A stove that burns pellets for 300 bucks is a bargain. New pellet stoves are going for as much as three thousand dollars. A CHEAP pellet stove is still more than a thousand dollars. The gear motor was the most expensive part of this project.. about \$140.00.

Startup can be a little tricky. First creat a draft by squirting some diesel oil or starting fluid into the COLD charcoal bed or put a bunch of paper in the lower chamber and light it. When a draft is established push an oil soaked, marble sized, wad of paper into one of the starting ports in the upper pyrolysis area. When that one is burning well, open the primary air valve and cap the starting port. Repeat the proceeedure for the second starting port. It takes a few minutes to get the air valves regulated but then you can just leave 'er be and not deal with it till it's time to add more fuel.

This is the lower chamber design that we started out with

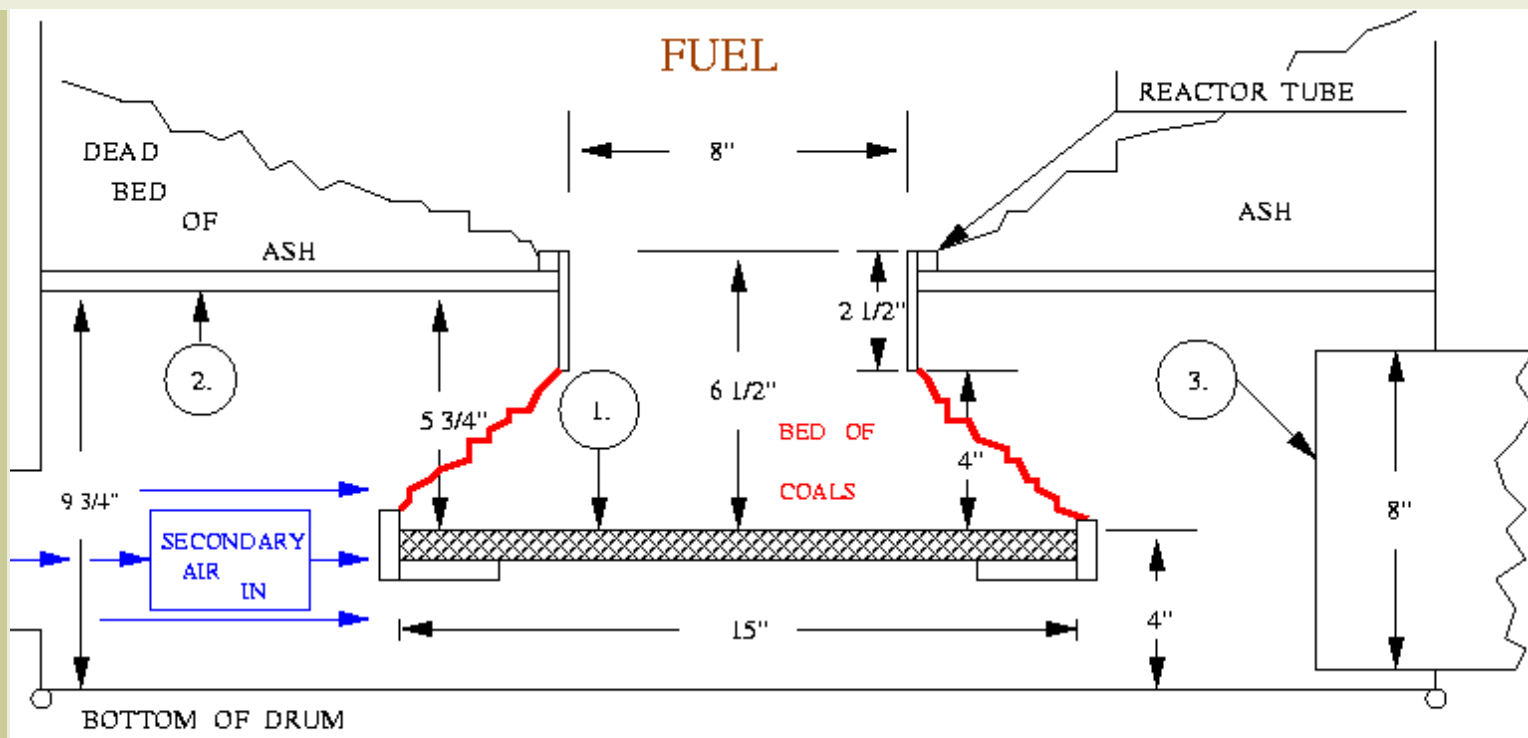

SECTIONAL VIEW THRU CENTER LINE OF STOVE

- 1. Heavy Duty Stainless Steel Wire Mesh with 3/16" openings.
- 2. Choke Plate is 3/8" mild steel.
- 3. Stainless Steel Tube connects to next drum.

**DIMENSIONS FOR NATURAL DRAFT
PRODUCER GAS HEATING STOVE.**

—BURNER DETAIL—

This first design followed the burner dimensions of a prototype wood gas stove stove that was built entirely within one 50 gallon drum. Needless to say the prototype did not have much fuel capacity, but it did prove that the concept would work.

The big problem with the first design is that it puts out too much heat for my small cabin. The other problems had to do with irregular fuel feed and un-coked wood getting into the bed of hot coals causing the amount of chimney smoke to increase.

The next series of tests had mostly to do with changes to the reactor tube size

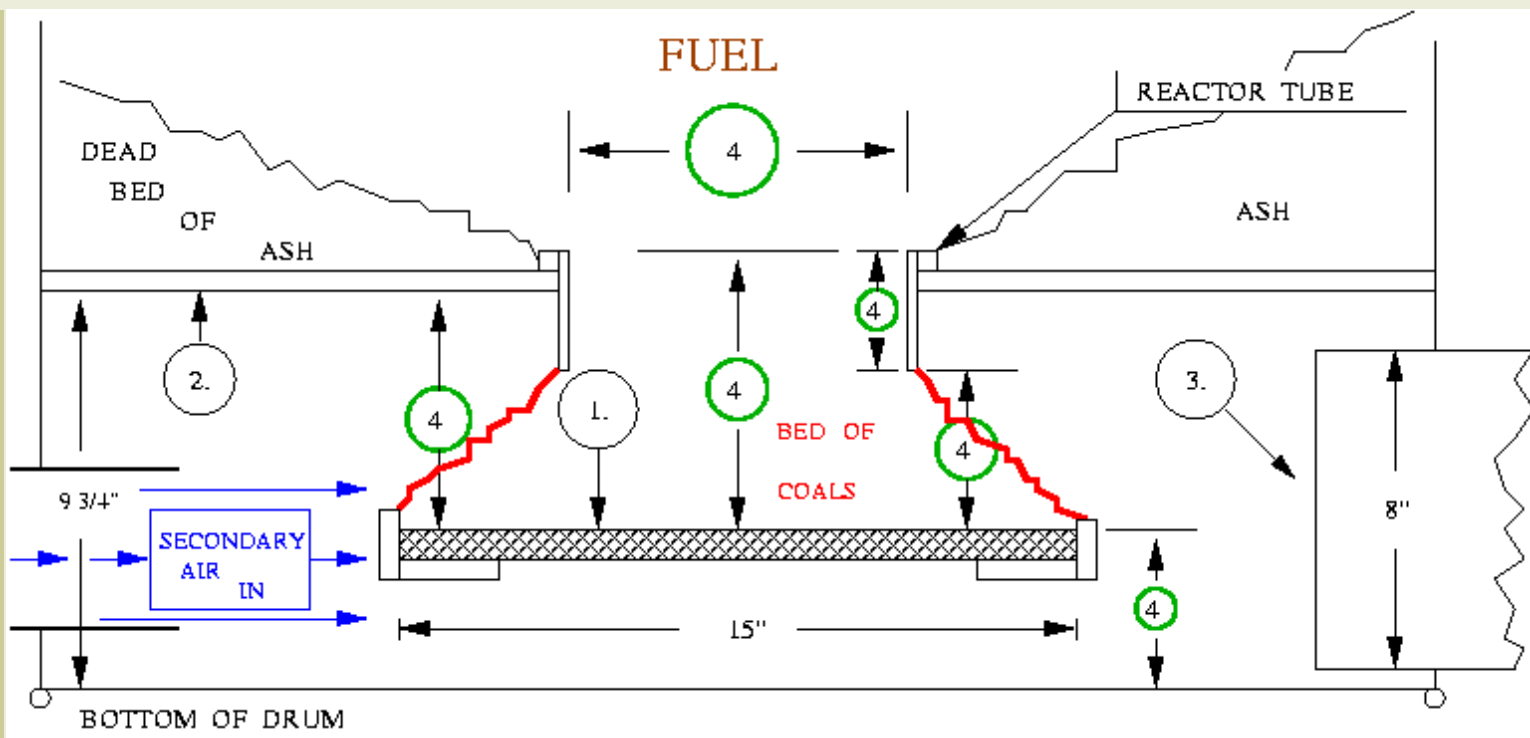

SECTIONAL VIEW THRU CENTER LINE OF STOVE

- 1. Heavy Duty Stainless Steel Wire Mesh with 3/16" openings.
- 2. Choke Plate is 3/8" mild steel.
- 3. Stainless Steel Tube connects to next drum.
- 4. See text for changes.

**DIMENSIONS FOR NATURAL DRAFT
PRODUCER GAS HEATING STOVE.**
——BURNER DETAIL——

Rev. 05-06-2005

This is information about the burner diagram revision dated 05-06-05.

The restrictor plate has a nine inch hole in it. The reactor tubes all have a collar welded to them so that they can be replaced when burned out. I now have a trio of reactor tubes that can be used to produce more or less heat. The table below will give you an estimation of how large a house can be heated with each size of reactor tube. Remember that the larger diameters really eat up the fuel.

Tube Dia.	House Size.
4"	750' sq.
5"	1,000' sq.
6"	1,500' sq.
8"	2,000' sq.

The reactor tubes are generally two inches deep.

The depth of the bed of hot coals is still about four inches.

The height of the grate was raised to five inches when using the four inch diameter reactor tube and wood pellets for fuel.

There were still problems with smoke at times and ash would accumulate on the grate deep enough to cause the heat output to drop. Also the large area of the pile of hot coals still caused raw fuel to fall into the center of what is supposed to be Hot Coals only.

ONE MORE TRY.

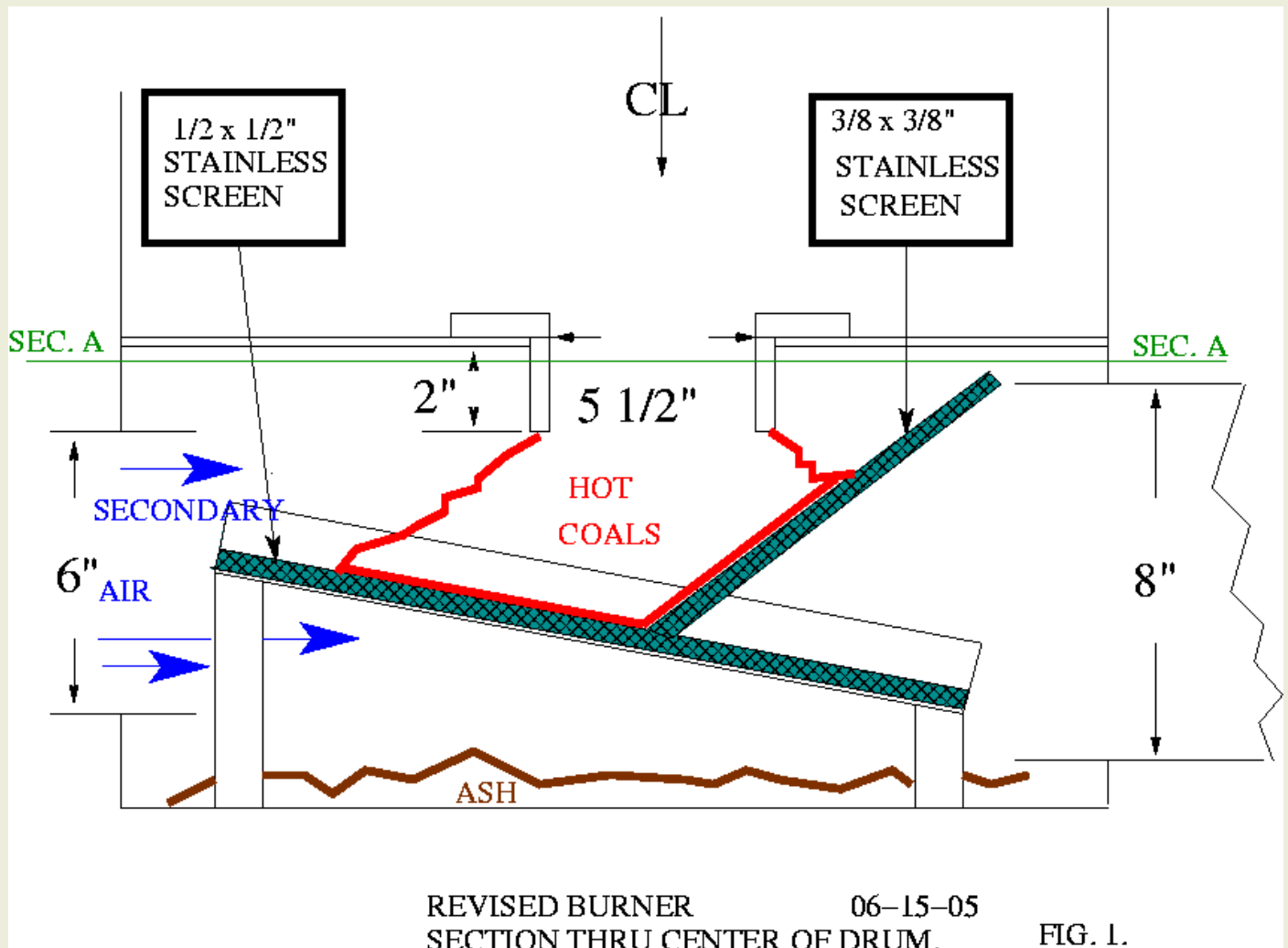

One of the things we did to lessen the amount of ash that accumulated on the grate was to use a larger mesh. Openings of 1/2" by 1/2" are large enough to let most of the ash build up drop thru. Trouble with the large holes is that wood pellets also drop thru easily. When starting up with pellets a paper towel is put on top of the grate and the pellets are dumped on the towel. When the towel burns thru the pellets are interlocked a bit and won't fall thru like before.

Also we made the horizontal area that the hot coals spread out on smaller by tilting the grate and adding another stainless steel wire screen that intersects the larger grate at an angle. This also has the effect of exposing the hot coals more directly to the secondary air stream. The more vigorous action of the air stream also cleans the grate of ash better. In order to channel the secondary air thru the hot coals better we put bricks on the grate to each side of the normal angle of repose of the hot coals. We tried to place the bricks in such a way as to close up the space thru which wood gas could migrate without going thru the hot coals.

The next diagram is a plan view at section "A" of fig. 1 looking down.

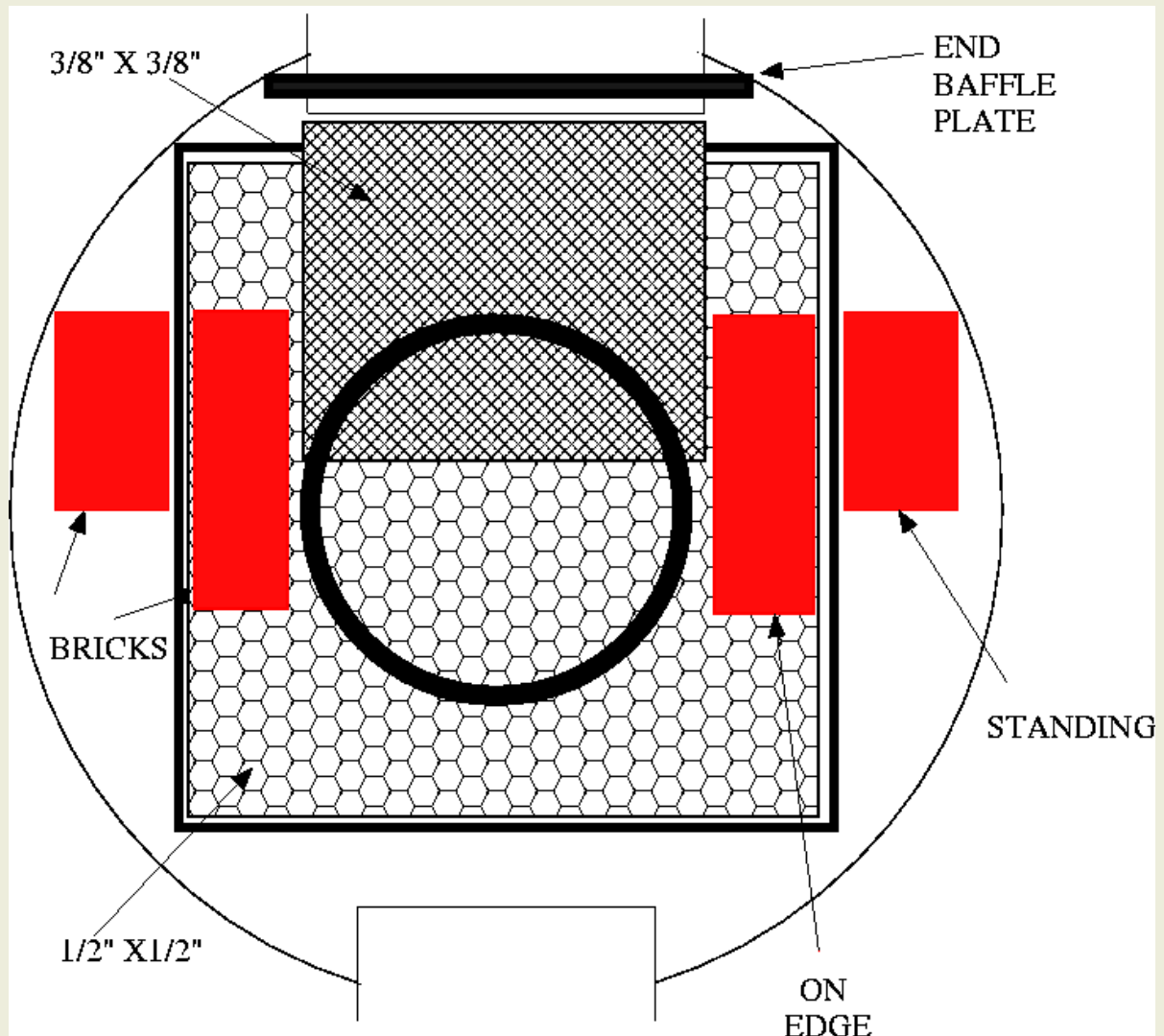

PROOF OF CONCEPT "CHUNKER"

I added an auxiliary blade to my wood splitter because the original one won't go forward enough. There is a fence that slides along with the new blade that limits the length of wood that the blade will cut to about an inch and a half. The fence has a cut out that lets the chunked wood fall away into a bucket under the log splitter.



Next is a view of the sliding fence and the cut out thru which the chunks fall.



This is what the "product" looks like.



What we are looking at above is chunked "squaw wood." It is the lower dead and dry limbs of pinon trees. It is called "squaw wood" because a squaw usually gathered it using only her hands or by whacking it with the poll of a "squaw axe." (Single bit axe.) Next is a view of "squaw wood" in the back of my truck.



"Squaw wood" has a low moisture content. It has usually been dead for a period of years and is still on the tree so that it has not picked up moisture from the ground. I measured the moisture content of various types of dead wood back in the early 80's when I was fiddling with my wood burning Cadillac. What I found was that the moisture content of dead snags and "squaw wood" was usually between 8 and 20 percent. Perfect for wood gas. What I would like to eventually do is construct a "chunker" that is automatic in operation and is oriented up and down so that the chunks fall down into a bucket.

By the way, back then I didn't have a log splitter. I made my fuel by cutting a round of dead, dry wood into a disk about two inches thick using a chain saw. I then put the disk on a chopping block and broke it into chunks with a hatchet. Kinda' slow, but it worked.

[Gasification] RE: Water Heaters

Tony Grimes [tgrimes at citlink.net](mailto:tgrimes@citlink.net)

Sat Nov 5 12:45:49 EST 2005

- Previous message: [\[Gasification\] Radial draft gasifier, plug flow - need advice](#)
 - Next message: [\[Gasification\] Kevin...](#)
 - Messages sorted by: [\[date \]](#) [\[thread \]](#) [\[subject \]](#) [\[author \]](#)
-

Hey Jeff,

Look in the Files section of the Yahoo Wood Gas group. I am working on a downdraft space heater made of 50 gal. drums and 3/8" plate. If you can cut and weld, you can build one. The first 50 gal. drum is the feed hopper and burner. The second 50 gal. drum is just a heat exchanger. You could build the hopper/burner and pipe the output directly to your boiler or build a boiler into the second drum.

Click on the link: "CLICK_ON_ME.HTML" and your browser will load a new web page. I'm just about ready to change the documentation again, as I've made some improvements to the burner design. Stay tuned!

(http://groups.yahoo.com/group/WoodGas/files/Heating_Stove/)

Good Luck and take care... tony

--

- Previous message: [\[Gasification\] Radial draft gasifier, plug flow - need advice](#)
 - Next message: [\[Gasification\] Kevin...](#)
 - Messages sorted by: [\[date \]](#) [\[thread \]](#) [\[subject \]](#) [\[author \]](#)
-

[More information about the Gasification mailing list](#)